



MR 329/2025

**DESIGN, MANUFACTURE, SUPPLY,
INSTALLATION AND COMMISSIONING OF
1.2MVAR 11kV THREE-PHASE CAPACITOR BANK
(SWITCHED-TYPE) AT EFL's KOROVOU POWER
STATION**

ENERGY FIJI LIMITED

© Copyright 2025

REVISION HISTORY & DOCUMENT CONTROL

Rev No.	Notes	Prepared By	Reviewed & Approved By	Date of Issue
0.1	Issued for Internal Review	ULSSP		19/07/17
0.2	Revised for Tender	KDP (ULSSP)		10/09/17
0.3	Revised for Tender	MZA (SPE)		27/06/23
0.4	Revised for Tender	RL (SPE) & MZA (MNDP)		28/11/25

TABLE OF CONTENTS

Contents

REVISION HISTORY & DOCUMENT CONTROL	2
1 INTRODUCTION AND SCOPE OF WORK	6
2 INSTRUCTIONS TO BIDDERS.....	7
2.1 Eligible Bidders.....	7
2.2 Eligible Materials, Equipment and Services.....	7
2.3 One Bid per Bidder.....	7
2.4 Cost of Bidding	7
2.5 Site Visits.....	7
2.6 Contents of Bidding Documents.....	7
2.7 Clarification of Bidding Documents	8
2.8 Amendment of Bidding Document	8
2.9 Language of Bid	8
2.10 Bid Prices	8
2.11 Bid Currencies.....	8
2.12 Bid Validity.....	8
2.13 Submission of Bids	9
2.14 Deadline for Submission of Bids.....	9
2.15 Late Bids.....	9
2.16 Modification and Withdrawal of Bids	9
2.17 Rejection of One or All Bids	9
2.18 Process to be Confidential	9
2.19 Clarification of Bids.....	10
2.20 Compliance with Specifications	10
2.21 Signature of Bidder.....	10
2.22 Insurance.....	10
3 GENERAL CONDITIONS OF CONTRACT	11
4 CONDITIONS OF PARTICULAR APPLICATION	12
5 REFERENCES.....	18
5.1 Applicable Standards	18
5.2 Applicable Laws.....	19
6 SERVICE CONDITIONS.....	19
6.1 Environmental Conditions and Mounting.....	19
6.2 System Conditions	20
6.3 Insulation Coordination.....	20
6.4 Harmonics	20
7 DESIGN AND PERFORMANCE CRITERIA.....	21
7.1 General.....	21
7.2 Capacitor Bank.....	21
7.3 Capacitor Unit.....	22
7.4 Capacitor Bank Rating Plate.....	22
7.5 Capacitor Protection.....	23
7.6 Vacuum Switch.....	23
7.7 Vacuum Switch Rating Plate	24
7.8 Reactor	24
7.9 Reactor Name Plate	24
7.10 Single Line Diagram, Protection Single Line Diagram and Control Drawing.....	24
7.11 Over-Voltage Protection and Surge Arrestors	25
7.12 Earthing and Lightning Protection.....	25
7.13 Ratings / Overload.....	25

7.14	Discharge Capability.....	26
7.15	Capacitor Bank Mounting Platform	26
8	CIVIL WORKS, INSTALLATION & OTHER SERVICES	27
8.1	Preliminary Works.....	27
	8.2.1 <i>Removing/Shifting existing equipment, dismantling steel structures</i>	27
	8.2.2 <i>Demolishing & removing of existing Masonry/concrete structures</i>	27
8.2	Control Cable Trenches & Ducts	27
8.3	Earthing Trenches & Reinstatement.....	27
8.4	Galvanized Steel Support Structures.....	27
	8.4.1 <i>General Requirements</i>	27
	8.4.2 <i>Minimum Galvanizing Requirements</i>	29
	8.4.3 <i>Painting of Galvanized Outdoor Steel Structures</i>	30
	8.4.4 <i>Transportation and Storage of Steelwork</i>	30
	8.4.5 <i>Erection</i>	30
	8.4.6 <i>Inspection and Tests</i>	30
	8.4.7 <i>Inspection and Testing of Paint</i>	30
	8.4.8 <i>Testing of Welding Operators</i>	31
	8.4.9 <i>Responsibility and Guarantees</i>	31
	8.4.10 <i>Factory Acceptance Testing</i>	31
8.5	Concrete Pad for Steel Structure Mounting	31
	8.5.1 <i>Concrete</i>	31
8.6	Chain Link Fence and Gate	32
9	TESTING.....	32
9.1	Type Tests.....	33
	9.1.1 <i>Capacitor Unit, Vacuum Switch and Reactor</i>	33
9.2	Routine Tests	34
	9.2.1 <i>Capacitor Unit, Vacuum Switch and Reactor</i>	34
9.3	Acceptance Tests	34
9.4	Witnessing of Tests.....	34
9.5	Test Certificates.....	35
10	TECHNICAL LITERATURE – OPERATIONS AND MAINTENANCE MANUALS	35
10.1	Plant Specification and Description	35
10.2	Installation and Commissioning	35
10.3	Operation.....	35
10.4	Maintenance.....	35
11	TRAINING.....	36
12	DESIGN REVIEWS.....	36
13	RELIABILITY	36
13.1	Service Life.....	36
13.2	Evidence in Support of Reliability.....	36
14	ENVIRONMENTAL CONSIDERATIONS	36
15	PACKAGING AND MARKING	36
16	QUALITY REQUIREMENTS	37
17	PRODUCT WARRANTY PERIOD	37
18	RECOMMENDED SPARES.....	37
19	SCHEDULE OF PRICES	38
19.1	Notes of Schedules.....	38
19.2	Schedule of Prices & Conditions of Payment.....	38
	19.2.1 <i>Contract Price</i>	38
	19.2.2 <i>Basis of Schedules</i>	38
	19.2.3 <i>Payment Terms</i>	38
19.3	Schedules of Rates & Prices	40
	19.3.1 <i>Notes on Schedules of Rates and Prices</i>	40

19.4 Drawings, Design and Documentation.....	41
19.5 Plant Equipment including Mandatory Spare Parts.....	42
19.6 Civil Works, Installation and Other Services	44
19.7 Grand Summary	46
20 INFORMATION TO BE SUPPLIED BY THE TENDERER	46
20.1 Documentation to be supplied with the tender.....	46
TENDER CHECKLIST	47
TENDER SUBMISSION - INSTRUCTION TO BIDDERS	48
APPENDIX A: SPECIFICATION REQUIREMENT.....	49
APPENDIX B: WORK PROGRAMME.....	49
APPENDIX D: SCHEDULE OF SUPPLEMENTARY INFORMATION	54
1 Tenderer’s Statement of Experience	54
2 Schedule of Financial Information.....	54
3 Personnel	54
4 Contractor’s Site Personnel	Error! Bookmark not defined.
5 CONTRACTOR HEALTH & SAFETY PLAN.....	54
6 PLANT & EQUIPMENT REGISTER	59
7 CONTRACTOR CHEMICAL REGISTER.....	59

1 INTRODUCTION AND SCOPE OF WORK

Energy Fiji Limited (“EFL”) is responsible for generation, transmission and distribution of electricity in Viti Levu, Vanua Levu, Ovalau and Tavueni in Fiji. By December 2024, the EFL had 223,539 customers. This included residential, commercial and institutional customers.

EFL is seeking tender bids from reputable manufacturers and suppliers for the complete design, manufacture, supply, installation and commissioning of outdoor type 1.2MVAR 11kV three-phase capacitor banks with automatic switching at EFL’s Korovou Power Station. The proposed outdoor type 1.2MVAR capacitor bank with automatic switching will be connected to existing 11kV indoor type switchboard. The existing 11kV switchboard is aged and is **not suitable for capacitive switching**, therefore, the capacitor bank switching shall be performed within external vacuum switch with reactor to limit inrush current. The capacitor bank shall be designed for automatic switching from 0MAVR to 1.2MVR in three (3) steps (or as proposed by the Tenderer subject to actual capacitor unit);

1. 0.4MVAR – Step 1
2. 0.8MVAR – Step 2
3. 1.2MAVR – Step 3

The 11kV capacitor bank and associated equipment and materials required are as follows:

1. 1.2MVAR (3x 0.4MVAR), 11kV three-phase capacitor bank
2. Vacuum switch with control wiring and complete panel for automatic switching
3. Reactor
4. Capacitor bank mounting platform with associated civil works for concrete pad
5. Capacitor bank earthing & associated 11kV power cabling between Vacuum switch, Reactor and Capacitor Bank
6. Construction of boundary fence

EFL will supply and install 300mm² 11kV 3C Al XLPE underground cable from existing 11kV switchboard inside control building to outdoor capacitor bank site. EFL will also carry out termination of 11kV power cable at 11kV switchboard. The Tenderer shall be responsible to supply termination kit and terminate 11kV power cable laid by EFL at capacitor bank bus bars.

The capacitor banks will be connected in star-configuration, with the star-point solidly earthed.

The Tenderer shall provide all electricity, water, gas and other services necessary to execute and complete the Works on site. Prevailing tariff and service connection procedure shall be applicable.

The contract also covers the maintenance for the defect liability period and all other works incidental thereto, whether specified in detail or not, necessary for securing efficient operation of the capacitor bank and associated equipment’s for a period of 24 months.

This tender specification outlines the instruction to bidders for design, manufacture, supply, installation, commissioning and performance criteria for the 11kV capacitor bank for EFL’s Korovou Power Station.

2 INSTRUCTIONS TO BIDDERS

2.1 Eligible Bidders

This invitation is open to all Bidders who have sound Financial Background, and have previous experience in design, manufacture, supply, installation and commissioning of switched-type 11kV outdoor capacitor banks.

Bidders shall provide such evidence of their continued eligibility satisfactory to EFL as EFL shall reasonably request. Bidders who are not manufacturers of such capacitor banks shall provide evidence of agency.

Bidders shall not be under a declaration of ineligibility for corrupt or fraudulent practice.

2.2 Eligible Materials, Equipment and Services

The materials, equipment, and services to be supplied under the Contract shall have their origin from reputable companies as specified by EFL and from various countries and all expenditures made under the Contract will be limited to such materials, equipment, and services. Upon request, bidders may be required to provide evidence of the origin of materials, equipment, and services.

For purposes of this Contract, "services" means the works and all related services including design and installation services.

For purposes of this Contract, "origin" means the place where the materials and equipment are mined, grown, produced or manufactured, and from which the services are provided. Materials and equipment are produced when, through manufacturing, processing or substantial or major assembling of components, a commercial recognized product results that is substantially different in basic characteristics or in purpose or utility from its components.

The materials, equipment and services to be supplied under the Contract shall not infringe or violate any industrial property or intellectual property rights or claim of any third party.

2.3 One Bid per Bidder

Each bidder shall submit only one bid. A bidder who submits or participates in more than one bid will cause all those bids to be rejected.

2.4 Cost of Bidding

The bidder shall bear all costs associated with the preparation and submission of its bid and EFL will in no case be responsible or liable for those costs.

2.5 Site Visits

A site visit is planned for 28th January 2026. Interested bidders are required to meet at EFL's Korovou Power Station at 11.00am. The GPS coordinates of the site is Latitude – 17°48'15.94" S and Longitude – 178°32'10.76" E.

2.6 Contents of Bidding Documents

The bidder is expected to examine carefully the contents of this Bidding document. Failure to comply with the requirements of bid submission will be at the bidder's own risk. Bids which are not substantially responsive to the requirements of the bidding documents will be rejected.

2.7 Clarification of Bidding Documents

A prospective bidder requiring any clarification of the bidding documents may notify EFL Supply Chain Office on phone (+679) 3224360 or (+679) 9992400 or email us on tenders@efl.com.fj. EFL will respond to any request for clarification which it receives earlier than 10 days prior to the deadline for submission of bids.

2.8 Amendment of Bidding Document

At any time prior to the deadline for submission of bids, EFL may, for any reason, whether at its own initiative or in response to a clarification requested by a prospective bidder, modify the bidding documents by issuing addenda.

2.9 Language of Bid

The bid, and all correspondence and documents related to the bid, exchanged between the bidder and the EFL shall be written in the English language.

2.10 Bid Prices

Unless specified otherwise, Bidders shall quote for the entire facilities on a "single responsibility" basis such that the total bid price covers all the Supplier's obligations mentioned in or to be reasonably inferred from the bidding documents in respect of the design, manufacture, supply, installation and commissioning.

Bidders shall give a breakdown of the prices in the manner and detail called for in the Schedules of Prices.

Bids shall be given on DDU to Suva Port, Fiji. In addition, estimated ocean freight charges, insurance, installation charges, the FOB price shall also be indicated separately in foreign currency and in local currency. Installation works and Other. After customs clearance, additional freight should be included to allow transfer of complete capacitor bank with associated equipment's and materials from Suva Port to project site at EFL's Korovou Power Station. Services shall include rates or prices for all labour, contractor's equipment, materials, consumables and all matters and things of whatsoever nature, the provision of operations and maintenance manuals, capacity building, etc. where identified in the bidding documents, as necessary for the proper execution of the Installation works and Other Services.

2.11 Bid Currencies

Prices shall be quoted in foreign and local currency as required in Price Schedule.

2.12 Bid Validity

Bids shall remain valid for a period of **180 days** from the date of Deadline for Submission of Bids.

2.13 Submission of Bids

Bidders are requested to upload electronic copies via Tender Link by registering their interest at: <https://www.tenderlink.com/efl>

EFL will not accept any hard copy submission to be dropped in the tender box at EFL Head Office in Suva.

For further information or clarification please contact our Supply Chain Office on phone (+679) 3224360 or (+679) 9992400 or email us on tenders@efl.com.fj.

The bidders must ensure that their bid is inclusive of all Taxes payable under Fiji Income Tax Act. Bidders are to clearly state the percentage of VAT that is applicable to the bid prices.

The lowest bid will not necessarily be accepted as the successful bid. The Tender Bids particularly the "Price" must be typed and not hand written. Any request for the extension of the closing date must be addressed to EFL in writing three (3) working days prior to the tender closing date. Tender Submission via email or fax will not be accepted.

2.14 Deadline for Submission of Bids

Bids must be received no later than **1600 hours (Fiji Time) 25th February, 2026**.

EFL may, at its discretion, extend the deadline for submission of bids by issuing an addendum, in which case all rights and obligations of EFL and the Bidders previously subject to the original deadline will thereafter be subject to the deadlines extended.

2.15 Late Bids

Any bid received by EFL after the deadline for submission of bids prescribed above will be rejected.

2.16 Modification and Withdrawal of Bids

The bidder may modify or withdraw its bid after bid submission, provided that written notice of the modification or withdrawal is received by EFL prior to the deadline for submission of bids.

No bid may be modified by the bidder after the deadline for submission of bids.

2.17 Rejection of One or All Bids

EFL reserves the right to accept or reject any bid, and to annul the bidding process and reject all bids, at any time prior to award of Contract, without thereby incurring any liability to the affected bidder or bidders or any obligation to inform the affected bidder or bidders of the grounds for the rejection.

2.18 Process to be Confidential

Information relating to the examination, clarification, evaluation and comparison of bids and recommendations for the award of a contract shall not be disclosed to bidders or any other persons not officially concerned with such process. Any effort by a bidder to influence EFL's processing of bids or award decisions may result in the rejection of the bidder's bid.

2.19 Clarification of Bids

To assist in the examination, evaluation and comparison of bids, EFL may, at its discretion, ask any bidder for clarification of its bid. The request for clarification and the response shall be in writing or by fax, but no change in the price or substance of the bid shall be sought, offered or permitted except as required to confirm the correction of arithmetic errors discovered by EFL in the evaluation of the bids.

2.20 Compliance with Specifications

The bid shall be based on the equipment and work specified and shall be in accordance with the Technical Specification. It should be noted that unless departures from specifications are detailed in Schedules of the Technical Specification, the bid would be taken as conforming to the Specification in its entirety. The Bidder shall tender for the whole of the Works included in the Specification.

2.21 Signature of Bidder

A tender submitted by a Partnership shall be signed by one of the members of the Partnership and shall be accompanied by a certified authorization of all the partners authorizing the individual partner to sign on behalf of the Partnership. A tender submitted by a Corporation to the Contract and shall be accompanied by a certified resolution of the Board of Directors authorizing the individual to sign on behalf of the Corporation.

2.22 Insurance

The bidder is to confirm that they have in effect the insurance policies below and provide copies of valid certificates with the bid:

1. Public and Products Liability Insurance
2. Professional Indemnity Insurance

3 GENERAL CONDITIONS OF CONTRACT

FIDIC

CONDITIONS OF CONTRACT FOR DESIGN- BUILD & TURNKEY

First Edition, 1995

A Publication of the International Federation of Consulting Engineers

Notes on the Conditions of Contract

The Conditions of Contract comprise two parts: Part I – General Conditions, and Part II – Conditions of Particular Application.

The International Federation of Consulting Engineers (FIDIC), has recently prepared the First Edition (1995) of Conditions of Contract for Design-Build and Turnkey Contracts. FIDIC Part I – General Conditions is included herein, complete and without any changes as Section 2 of these documents.

Copies of the FIDIC Conditions of Contract can be obtained from:

FIDIC Secretariat

P.O. Box 86

1000 Lausanne 12

Switzerland

Facsimile: 41 21 653 5432

Telephone: 41 21 653 5003

4 CONDITIONS OF PARTICULAR APPLICATION

Sub-Clause 1.1 Definitions		<p>Amend subpara 1.1.1.3 of Sub-Clause 1.1 by adding the following words at the end:</p> <p>"The word 'tender' is synonymous with bid'."</p> <p>Amend subpara 1.1.1.4 of Sub-Clause 1.1 by adding the following words at the end:</p> <p>"The words 'Appendix to Tender' are synonymous with the words 'Appendix to Technical Proposal' and 'Appendix to Price Proposal'."</p> <p>Add the following subparagraph to Sub-Clause 1.1:</p> <p>"1.1.2.7 "EFL" means the Energy Fiji Limited."</p>
Sub-Clause 1.4 Law and Language		<p>Replace the text of Sub-Clause 1.4 and add the following:</p> <p>"The Contract shall be governed by and construed in accordance with the Laws of Fiji. The language is the English language."</p>
Sub-Clause 1.5 Contract Agreement		<p>Substitute the wordings in Part I with the following:</p> <p>"A Contract Agreement in the form annexed, with such modifications as may be necessary to record the agreement reached shall be executed. The costs of stamp duties and similar charges imposed by the law shall be borne by the Employer."</p>
Sub-Clause 1.6 Priority of Documents		<p>Replace the list of documents listed under (a) to (h) and add the following:</p> <p>"(a) the Contract Agreement; (b) the Letter of Acceptance; (c) the Employer's Requirements; (d) the Bid; (e) the Conditions of Contract, Part II; (f) the Conditions of Contract, Part I; (g) the Schedules; (h) the Drawings; (i) the Correspondences During Tender Evaluation; (j) the Contractor's Proposal. "</p>
Sub-Clause 1.15 Confidentiality		<p>Additional sub-clause: "The Contractor shall treat the details of the Contract as private and confidential, except to the extent necessary to carry out its obligations under it. The Contractor shall not publish, permit to be published or disclose any particulars of the Contract in any trade or technical paper or elsewhere without the prior consent in writing of the Employer."</p>
Sub Clause 2.5 Customs and Import Duties		<p>(a) The Employer shall pay for all Fiji customs and import duties including clearing, handling charges, port dues and demurrage except only for customs and import duties in respect of tools required for installation, testing and commissioning, which shall be the responsibility of the Contractor.</p> <p>(b) Customs and import duties if any in respect of the Contractor's Equipment shall not be borne by the Employer.</p>
Sub-Clause 3.1 Employer Representative's Duties and Authority		<p>Add the following clause as required:</p> <p>"The Employer's Representative shall obtain the specific approval of the Employer before taking action under the following clauses of the Conditions of Contract Part I.</p>

- (a) approving sub-contracting of any part of the Works under Sub-Clause 4.5.
- (b) certifying additional cost to the Contract Price.
- (c) granting an extension of time for completion under Sub-Clause 8.3.
- (d) suspending progress of part or all of the Works under Sub-Clause 8.8.
- (e) issuing a variation under Clause 14, except if such a variation would increase the Contract Price by no more than FJD 50,000.
- (f) issuing Taking-Over Certificate for the whole of the Works under Sub-Clause 10.1.
- (g) issuing Performance Certificate for the Works under Sub-Clause 12.9.

Notwithstanding the obligation to obtain approval as set out above, if in the opinion of the Employer's Representative, an emergency occurs affecting the safety of life or of the Works or of adjoining property, it may, without relieving the Contractor of any of its duties and responsibilities under the Contract, instruct the Contractor to execute all such work or to do all such things as may, in the opinion of the Employer's Representative be necessary to abate or reduce the risk. The Contractor shall forthwith comply with the instructions of the Employer's Representative despite the absence of approval of the Employer. The Employer's Representative shall determine the extra cost to the Contractor for carrying out of such instruction and obtain the Employer's approval for an addition to the Contract Price."

Sub-Clause General Obligations	4.1	<p>Add the following sentence to precede the existing text under Sub-Clause 4.1:</p> <p>"Notwithstanding any other provision to the contrary, the Contractor is required to check the design criteria and calculations (if any) included in the Employer's Requirements, to confirm their correctness, in its bid and to assume full responsibility for them."</p>
Sub-Clause Performance Security	4.2	<p>Replace the first paragraph of Sub-Clause 4.2 with the following:</p> <p>"The Contractor Shall provide security for its proper performance of the Contract to the Employer within 28 days after the receipt of the Letter of Acceptance. The performance security shall be in the form of a bank guarantee, issued either (a) by a bank located in the country of the Employer or a foreign bank through a correspondent bank located in the country of the Employer, or (b) directly by a foreign bank acceptable to the Employer. The performance security shall be denominated in the types and proportions of currencies in which the Contract Price is payable. When providing such security to the Employer, the Contractor shall notify the Employer's Representative of so doing."</p>
Sub-Clause Contractor's Representative	4.3	<p>At the end of Sub-Clause 4.3 add:</p> <p>"The Contractor's Representative must be fluent (both spoken and written) in the English language."</p>
Sub-Clause Co-ordination of the Works	4.4	<p>Modify the first sentence of Sub-Clause 4.4 to read:</p> <p>"The Contractor shall be responsible for the co-ordination and proper execution of the Works, including co-ordination with other contractors and</p>

organizations to the extent specified in the Employer's Requirements."

Sub-Clause 4.9 Site Data		Modify the last sentence of paragraph 1 of Sub-Clause 4.9 to read: "The Contractor shall be responsible for interpreting all data including data listed elsewhere in the Contract as open for inspection at EFL, Korovou Power Station, Fiji".
Sub-Clause Programme	4.14	Delete the third sentence of Sub-Clause 4.14 indicated below: "Unless otherwise stated and late finish dates".
Sub-Clause Construction Documents	5.2	In the fifth line of the second paragraph of sub-clause 5.2 replace "21" with "28". In Sub-Clause 5.2 delete sub-paragraph (a) and substitute: "(a) Construction shall not commence until the Contractor receives from the Employer's Representative approval of the Construction Documents relevant to the design and construction of such parts; provided always that: if the Employer's Representative fails to give his ruling within 21 days, the Contractor shall give written notice (for the purpose of this sub-clause "Contractor's Notice") to the Employer's Representative of such failure; and if the Employer's Representative fails to give his ruling within 7 days of receipt of the Contractor's Notice, then the Contractor may proceed with the construction as though approval had been given".
Sub-Clause Technical Standards & Regulations	5.4	Add the following sentence to the end of the Sub-Clause 5.4: "In respect of technical specifications and standards, IEC (International Electrotechnical Commission based in 3, rue de Varembe, PO Box 131, CH-1211 Geneva 20, Switzerland) standards are to be adopted in general. Any national or international standards which promise to confer equal or better quality than the standards specified will also be acceptable. In all instances a copy of the relevant standards should be forwarded to the Employer's Representative".
Sub-Clause Health and Safety	6.7	To sub-clause 6.7 add the following paragraph: The Contractor must, at all times during the execution of the Work, comply with the Health and Safety at Work Act 1996, the Electricity Act Cap 180, the Energy Fiji Limited "Safety Manual" – Safety Rules and First aid For Employees Of the Authority.
Sub-Clause Contractor's Superintendence	6.8	At the end of Sub-Clause 6.8 add: "All the Contractors superintending staff shall have a working knowledge of the English language."
Sub-Clause Foreign staff and Labour	6.11	"The Contractor may import such staff, and labourers as are required in order to execute the Works. The Contractor must ensure that all such staff and labour are provided with the required visas and work permits. The Contractor shall be responsible for the return to the place where they were recruited or to their domicile of all persons whom the Contractor recruited and employed for the purpose of or in connection with the Contract. The Contractor shall be responsible for such persons as are to be returned until they shall have left the Site or, in the case of foreign nationals who have been recruited outside the Country, shall have left it."
Sub-Clause Measures against Insect & Pest Nuisance	6.12	"The Contractor shall at all times take the necessary precautions to protect all staff and labour employed on the Site from insect and pest nuisance, and to reduce the dangers to health and the general nuisance occasioned by the same. The Contractor shall provide its staff and labour

with suitable prophylactics for the prevention of malaria and dengue fever and take steps to prevent the formation of stagnant pools of water. The Contractor shall comply with all the regulations of the local health authorities and shall arrange to spray thoroughly with approved insecticide all buildings erected on the Site. Such treatment shall be carried out at least once a year or as instructed by such authorities."

Sub-Clause Epidemics	6.13	"In the event of any outbreak of illness of an epidemic nature, the Contractor shall comply with and carry out such regulations, orders and requirements as may be made by the Government or the local medical or sanitary authorities, for the purpose of dealing and overcoming the same."
Sub-Clause Alcoholic Liquors or Drug	6.14	"The Contractor shall not import, sell, give, barter or otherwise dispose of any alcoholic liquor or drugs, or permit or suffer any such importation, sale, gift, barter or disposal by his Subcontractors, agents staff or labour."
Sub-Clause Arms and Ammunition	6.15	"The Contractor shall not give, barter or otherwise dispose of to any person or persons, any arms or ammunition of any kind or permit or suffer to the same as aforesaid."
Sub-Clause Burial of the Dead	6.16	The Contractor shall make all necessary arrangements for the transport, to any place as required for burial, of any of his expatriate employees or members of their families who may die in the Country. The Contractor shall also be responsible, to the extent required by local regulations, for making any arrangements with regard to burial of any of his local employees who may die while engaged upon the Works.
Sub-Clause Festivals and Religious Customs	6.17	"The Contractor shall in all dealings with his staff and labour have due regard to all recognized festivals, days of rest and religious or other customs."
Sub-Clause Inspection	7.3	To sub – clause 7.3 add the following paragraphs: The Employer and the Contractor shall carry out a joint walk through inspection to identify and document any defects/ deficiencies of the Works prior to commissioning, after which the Contractor shall rectify all the identified defects. The Employer and the Employer's Representative shall be entitled at any time during the term of this Contract to inspect any part of the Works and the Contractor shall give them full opportunity and access to conduct such inspection.
Sub-Clause Restriction on Eligibility	7.7	(a) Any materials, equipment, services or design services which will be incorporated in or required for the Contract, as well as the Contractor's Equipment and other supplies, shall have their origin from reputable source countries acceptable to the Employer. (b) For the purpose of this clause, "services" means the works and all project-related services including design services. (c) For the purposes of this clause, "origin" means the place where the materials and equipment were mined, grown, produced, or manufactured, or from which the services are provided. (d) The origin of Goods and Services is distinct from the nationality of the Supplier."
Sub-Clause Warranty	12.11	"The Employer shall be entitled to all applicable manufacturers' warranties for the Plant and equipment supplied by the Contractor. The Contractor warrants the Equipment to be free from defects in workmanship and material used in their manufacture and

installation. This warranty will cover Equipment for claims for such defects and workmanship made during the Warranty Period, being 12 months from completion of defects liability period and issuing of performance certificate

Sub-Clause 13.2
Advance Payment

Modify the third sentence of this Sub-Clause to read:

"The Employer's Representative shall issue an Interim Payment Certificate for the first instalment after (i) execution of the Contract Agreement by the parties hereto (ii) provision of the Performance Security in accordance with Sub-Clause 4.2 by the Contractor and (iii) provision of an unconditional bank guarantee by the Contractor in a form and by a bank acceptable to the Employer in amounts and currencies equal to the advance payment."

Sub-Clause 13.4
Schedule of
Payments

To Sub-Clause 13.4 add:

The payments will be made according to the following schedule:

* EFL will assess during tender evaluation

Sub-Clause 13.15
Calculation of
Payments in
Foreign Currency

Delete Clause 13.15 and add the following:

"The Contract shall be paid in the currencies stated in the Appendix to Bid and shall be in accordance with Schedule of Prices and Conditions of Payment.

The foreign and local currency portions of the balance of the Contract Price shall be amended by agreement between the Employer and the Contractor to reflect any substantial changes in the expected foreign and local currency requirements of the Contractor during the execution of the Works, provided:

(a) the Contractor shall inform the Employer and the Employer's Representative whenever any such substantial change may occur;

(b) the Employer's Representative may recommend a review of such expected requirements if in its judgment there is evidence of a change in the country of origin of equipment, materials, plants, or services to be provided under the Contract which should result in any substantial change of such expected requirements.

Any such amendment shall be affected by comparing the amounts quoted in the bid with the amounts already used in the Works and the Contractor's future needs for imported items."

Sub-Clause 13.15
Calculation of
Payments in
Foreign Currency

To sub-clause 13.15 add the following paragraph:

The local (Fijian) component of the Contract Price shall not be subjected to any currency exchange rate variation.

Sub-Clause 13.17
Taxation

"(i) The prices bid by the Contractor shall include all taxes, duties and other changes imposed outside the Employer's country on the production, manufacture, sale and transport of the Contractor's equipment, Plant, materials and supplies to be used on or furnished under the Contract, and on the services performance under the Contract.

Sub-Clause 15.5
Corrupt or
Fraudulent
Practices

Delete the existing Sub-Clause 15.5 and substitute the following:

"If in the judgment of the Employer the Contractor has engaged in corrupt or fraudulent practices, in competing for or in executing the Contract, then the Employer may, after having given 14 days' notice to the Contractor, terminate the Contractor's employment under the Contract and expel the

Contractor from the Site, and the provisions of Clause 15 shall apply as if such expulsion had been made under Sub-Clause 15.2."

Sub-Clause 17.3
Employer's
Risks

This sub-clause is amended to read as follows:

"The Employer's risks are:

(a) insofar as they directly affect the execution of the Works in the country where the Permanent Works are to be executed:

(i) war and hostilities (whether war be declared or not), invasion, act of foreign enemies in the Country;

(ii) rebellion, revolution, insurrection, or military or usurped power, or civil war in the Country;

(iii) ionizing radiations, or contamination by radioactivity from any nuclear fuel, or from any nuclear waste from the combustion of nuclear fuel, radioactive toxic explosive or hazardous properties of any explosive nuclear assembly or nuclear component thereof in the Country;

(iv) pressure waves caused by aircraft or other aerial devised travelling at sonic or supersonic speeds in the Country;

(v) riot, commotion or disorder, unless solely restricted to the employees of the Contractor or of its Subcontractors and arising from the conduct of the Works in the Country;

(b) loss or damage due to the use or occupation by the Employer of any Section or part of the Permanent Works, except as may be provided for in the Contract;

(c) any operation of the forces of nature (insofar as it occurs on the Site) which an experienced Contractor:

(i) could not have reasonably foreseen, or

(ii) could reasonably have foreseen, but against which he could not reasonably have taken appropriate measures to prevent loss or damage to physical property occurring."

Sub-Clause 18.2
Insurance for
Works and
Contractor's
Equipment

(i) Amend the second sentence of the first and second paragraphs to read:

"This insurance shall cover loss or damage from any cause other than the Employer's risks listed in amended Sub-Clause 17.3 paras. (a)(i) to (iv) in Part II of the Conditions of Contracts".

(ii) Amend the fourth sentence of the first paragraph to read:

"Such insurance shall cover the Employer and the Contractor from the first working day after the Commencement Date until the date of issue of the Taking-Over Certificate for the Works."

5 REFERENCES

5.1 Applicable Standards

Capacitor banks shall be designed, manufactured, tested, installed and commissioned in accordance with the following Australian and International Standards and all amendments issued prior to the date of closing of tenders except where varied by this Specifications.

AS 1100	Drawing Practice Scales – Part 7
AS 1194	Winding Wires Parts 1 – 4
AS 1265	Bushings for Alternating Voltages Above 1 000 V
AS 1580	Methods for Test for Paints and Other Related Materials
AS 1627	Metal Finishing – Preparation and Pretreatment of Surfaces
AS 1650	Galvanized Coatings
AS 1824	Insulation Co-Ordination
AS 1931	High voltage testing techniques – Part 1
AS 2067	Substations and high voltage installations exceeding 1 kV a.c.
AS 2312	Guide to Protection of Iron and Steel Against Exterior Atmospheric Corrosion
AS 2344	Limits of electromagnetic interference from overhead A.C. Powerlines and high voltage equipment installations in the frequency range 0.15 to 1000 MHz
AS 2700	Colour standards for general purposes
AS/NZS 3750	Paints for Steel Structures
AS 4398	Insulators – Ceramic or Glass – Station Post for Indoor and Outdoor Use – Voltages greater than 1 000V a.c.
AS 4680	Hot-dip galvanized (zinc) coatings on fabricated ferrous articles
AS/NZS 9001	Quality Systems Model for Quality Assurance in Design, Development, Production, Installation and Servicing
AS 60529	Degrees of protection provided by enclosures
AS 62271.1	High-voltage switchgear and controlgear - Common specifications
AS 62271.100	High-voltage switchgear and controlgear - High-voltage alternating-current circuit-breakers
AS 62271.200	High-voltage switchgear and controlgear - A.C. metal-enclosed switchgear and controlgear for rated voltages above 1kV and up to and including 52kV
AS 62271.201	High-voltage switchgear and controlgear - AC insulation-enclosed switchgear and controlgear for rated voltages above 1 kV and up to and including 52 kV
AS/NZS 3947	Low voltage switchgear and control gear, (all relevant parts)
IEC 60099.4	Surge arresters – Part 4: Metal-oxide surge arresters without gaps for a.c. systems
IEC 60216	Electrical insulating materials
IEC 60871.1	Shunt capacitors for AC power systems having a rated voltage above 1000 V – Part 1 General
IEC 60871.2	Shunt capacitors for AC power systems having a voltage rating above 1000 V – Part 2: Endurance testing
IEC 60871.4	Shunt capacitors for AC power systems having a rated voltage above 1 000 V – Part 4: Internal fuses
IEEE Std. 18	Standard for Shunt Power Capacitors

Should inconsistencies be defined between Standards and the Specifications, this Specification will take precedence. However, significant inconsistencies shall be referred to EFL for resolution.

5.2 Applicable Laws

The Tenderer warrants (without limiting any other warranties or conditions implied by law) that all Goods have been produced, sold and delivered to EFL in compliance with all applicable laws (including all workplace health and safety and electrical safety legislations and codes of conduct).

6 SERVICE CONDITIONS

6.1 Environmental Conditions and Mounting

The capacitor banks and associated equipment's shall be suitable for outdoor installation. It shall be designed to withstand the service conditions of Clause 2 of AS 62271.1, with the following additions.

Height above sea level	:	not exceeding 1000 m
Atmosphere	:	Saliferous, corrosive and dusty
Ambient temperature	:	Peak : 40°C
	:	24 Hour Average: 29°C
	:	Annual Average: 29°C
	:	Minimum: 10°C
Relative Humidity (Average)	:	90%
Rainfall	:	Annual Average: 2200 mm
Maximum Wind Speed	:	85m/s
Isokeraunic Level	:	60 Thunder days per year
Seismic	:	To a maximum of 7 on the open-ended Richter Scale

Note: Fiji is situated in a region where cyclones are experienced frequently. All plant and equipment shall be designed and constructed to withstand these extreme conditions. All plant and equipment shall be rust proof, vermin proof and weather proof and designed to be suitable for a damp, tropical climate, which may be experienced simultaneously.

All ferrous parts shall be treated to provide acceptable surface finish and protection. The manufacturer shall provide full details of the surface finish provided. Where required, equipment may need to be raised or have extra treatment to minimize corrosion on all metal components, particularly those in contact with the plinth.

The equipment shall include everything necessary or usually supplied for the operation, whether directly specified or not.

The insulation level shall be in accordance with the technical requirements stated. All insulation shall be of a type and quality that will give normal life expectancy without deterioration.

6.2 System Conditions

The rated frequency of EFL's power system is 50 Hz. Each unit shall be suitable for use on its respective system position.

Highest (Equivalent) System Voltage:	12kV
Number of phases:	3
Impulse Withstand voltage (peak):	75kV
Power frequency withstand voltage:	28kV (peak)
Nominal system voltage:	11kV
System highest voltage:	12kV
System earthing:	Effectively earthed
Short Circuit Current	25kA

6.3 Insulation Coordination

Suitable insulation levels and method of system earthing are required as detailed in this specification.

6.4 Harmonics

The capacitor bank(s) shall not in any way amplify or contribute to increasing the harmonic distortion at the point of connection. **The Supplier shall submit evidence to substantiate this.**

7 DESIGN AND PERFORMANCE CRITERIA

7.1 General

The outdoor type capacitor bank with automatic switching will be installed at EFL's Korovou Power Station at the 11kV busbar ("point of connection") via existing indoor circuit breaker to cost effectively improve the power factor.

The capacitor banks supplied and installed shall conform to all the current requirements of:

- IEC60871.1 for capacitor units, and
- all relevant Australian and IEC Standards and this specification.

The Tenderer shall provide everything necessary, including any special tools, usually supplied for the safe operation of the equipment, whether directly specified or not.

The design, manufacture, supply, installation and commissioning shall be in accordance with the technical requirements stated. All materials shall be of a type and quality that will give a normal life expectancy of 45 years.

The equipment and its components shall be designed in a manner to reduce the risk of rupture and explosive failure and subsequent fire risk. The appropriate sizing and locations of any pressure relief devices/rupture points shall be key considerations in the design and be specifically addressed by the designer in the design review. Suggested routine testing and maintenance regimes and limits shall be provided to manage ongoing risk of equipment or component failure.

Equipment/components from third party suppliers, such as surge arresters, control relays/devices and the like shall not be modified without written approval from the General Manager Network and General Manager System Planning and Control.

The Tenderer shall be responsible for all insurance relating to the equipment until the point of handover. The Tenderer shall pay all duty, taxes, freight, cartage and all other charges in this process. All network access, business hours, insurances, traffic control, stakeholder management, site access and all duties required to safely meet these requirements are the responsibility of the Tenderer.

The Tenderer shall ensure the equipment design and selection interfaces well with existing DC supply system and SCADA. The National Control Centre in Vuda, Lautoka should be able to view real-time status of capacitor bank.

7.2 Capacitor Bank

11kV three phase capacitor bank shall have a net output of 1.2MVAR and the unit may be conveniently arranged according to the standard practice of the manufacturer including switching mechanism and type of protection offered. The switching in and out of the bank shall be by means of vacuum switch provided by the tenderer as existing 11kV indoor circuit breaker is **not suitable** for capacitive switching.

The capacitor units and associated equipment's shall be compactly designed in size and weight to be conveniently mounted to platform structure. The housing shall have a rugged and reliable construction for outdoor mounting. Detailed design calculations and construction drawing are required for EFL approval prior to tenderer's procurement of materials and construction. The associated civil works for the construction of outdoor mounting platform shall be carried out in accordance to relevant standards and requirement of this specification.

The guaranteed minimum values of losses of the capacitor units shall include losses due to discharge resistors which may be mounted inside each unit to discharge each unit from peak voltage to maximum 75V in less than 10 minutes.

Internal fuses shall be provided in order to limit possible failure to a single capacitor element only. Internal fuses shall be provided for several individual elements within each unit. The internal fuses shall comply with IEC 60593 standards. The tolerances and the degree of unbalances shall also be indicated as per relevant standards. The capacitors shall be able to carry continuously 1.3 times the rated current, 1.1 times the maximum system voltage and shall provide continuously 1.35 times the rated output. All the above requirements shall be fulfilled under maximum ambient temperature.

The dielectric material shall consist of an all film material being suitable to operate the capacitors on continuous load under the specified ambient conditions, having high stability and low loss per kVAR. The impregnate shall be of a hydrocarbon type fluid characterized by high electrical strength and adequate physical and chemical properties and shall be non-PCB.

Each capacitor shall be hermitically sealed and have two bushings. A creepage distance of 50 mm/kV for open rack mounted for outdoor installation. The capacitor shall be designed for low working stress per micron to ensure larger life and low loss per kVAR.

The arrangement of the fixing and the bushings shall be identical in order to easily exchange and replace any capacitor element of the total capacitor bank. The terminals for bushings and fixing elements shall be ISO standard (metric).

7.3 Capacitor Unit

The capacitance of the segment is realized by connecting capacitor units in series and parallel to provide the required capacitive reactance with the continuous current rating. The capacitors shall be designed to withstand higher currents such as those experienced during emergency loadings (typically the 30-min. rating), system swings and during faults as specified by EFL.

The capacitor units shall be designed to withstand the specified continuous rated current, emergency loading, swing current and power system faults with the maximum capacitor unbalance condition for which the control and protection system will allow the bank to remain in service.

If capacitor fuses are used, either internally or externally, the fuses should be designed to operate correctly for bank currents of 50% of rated current up to and including power system fault conditions.

7.4 Capacitor Bank Rating Plate

The following minimum information shall be provided by the manufacturer on the nameplate of each capacitor bank:

- EFL tender number
- Name of the manufacturer
- Place of manufacture
- Standards to which the capacitor bank complies to
- Rated output QN in kVAR - total output to be given.
- Rated voltage UN in kilovolts
- Insulation level (UI) - The insulation level shall be marked by means of two (2) numbers separated by a stroke, the first number giving the r.m.s. value of the rated power frequency

short duration voltage in kiloVolts, and the second number giving the peak value of the rated lightning impulse withstand voltage in kiloVolts

- Connection symbol - A standard connection symbol may be selected from clause 25.2 of IEC 60871-1.
- Minimum time required between disconnection and reconnection of the bank.
- Time to discharge to 75V
- Year of manufacture
- Sound Level

The rating plate shall be stainless steel to grade 316, and shall be located on the longer side of the capacitor bank.

7.5 Capacitor Protection

The capacitor banks/units protection shall meet all the requirements of IEC 60871-3 and that of this specification. They shall be provided completely with internal and external protection which is considered as part of the capacitor equipment.

Fuses shall be provided internally for protection of individual capacitor units. The fuses shall not deteriorate when the capacitor is subjected to discharge testing or the currents associated with service operations of the capacitor equipment. The Tenderer shall provide fuse rupturing curves to EFL.

Fuses shall only rupture in case the related unit is subject to failure and shall be capable of breaking the current following a failure of the capacitor unit without hazard from the fuse or the capacitor.

The ruptured fuse of each element shall withstand indefinitely the voltage imposed across it under all operating conditions.

The remaining capacitor units shall be able to operate within the capacitor bank without undue disturbance for a present number of unit capacitor failures.

The Tenderer must provide the following in his bid for tender evaluation:

- a) Calculation of constrains subjected to capacitor units.
- b) The fuse time current coordination curve.
- c) Recommendation of fusing to provide a satisfactory probability against case rupture.

Further to a fuse operation, there must not be any excessive leakage current nor any risk of sparking when a full voltage is permanently applied between the bus bar and the defective capacitor unit terminal, and such for all specified atmospheric conditions.

7.6 Vacuum Switch

The vacuum switch shall be designed, manufactured, tested, installed and commissioned for automatic capacitive switching. The control system shall be accordingly designed to monitor voltage level of 11kV bus at Korovou PS and switch in/out capacitor banks in stages with relevant time-delays to avoid fast switching. If required, EFL will provide historical load and voltage profiles of 11kV bus at Korovou PS for appropriate system design and analysis. The vacuum switch shall be designed for automatic switching of capacitor bank from 0MAVR to 1.2MVR in three (3) steps (or as proposed by the Tenderer subject to actual capacitor unit);

1. 0.4MVAR – Step 1
2. 0.8MVAR – Step 2
3. 1.2MAVR – Step 3

7.7 Vacuum Switch Rating Plate

The following minimum information shall be provided by the manufacturer on the nameplate of each vacuum switch:

- EFL tender number
- Name of the manufacturer
- Place of manufacture
- Standards to which the Vacuum Switch complies to
- Capacitive Switching Capability.
- Rated voltage UN in kilovolts
- Insulation level (UI) - The insulation level shall be marked by means of two (2) numbers separated by a stroke, the first number giving the r.m.s. value of the rated power frequency short duration voltage in kiloVolts, and the second number giving the peak value of the rated lightning impulse withstand voltage in kiloVolts
- Connection symbol - A standard connection symbol may be selected from clause 25.2 of IEC 60871-1.
- Year of manufacture
- Sound Level
- Other important details of Vacuum Switch

The rating plate shall be stainless steel to grade 316, and shall be located on the longer side of the Vacuum Switch or where it is easily visible.

7.8 Reactor

The reactor shall be designed, manufactured, tested, installed and commissioned to limit inrush current and detune harmonics during automatic switching of capacitor banks. Where iron-core reactors are utilized they must be mounted at ground level on a common frame. Alternatively, where air-core reactors are utilized they must be stacked above each other and mounted on a common structure;

7.9 Reactor Name Plate

The following minimum information shall be provided by the manufacturer on the nameplate of each capacitor bank:

- EFL tender number
- Name of the manufacturer
- Place of manufacture
- Standards to which the Reactor complies to
- Inrush Withstand Capability.
- Rated voltage UN in kilovolts
- Insulation level (UI) - The insulation level shall be marked by means of two (2) numbers separated by a stroke, the first number giving the r.m.s. value of the rated power frequency short duration voltage in kiloVolts, and the second number giving the peak value of the rated lightning impulse withstand voltage in kiloVolts
- Connection symbol - A standard connection symbol may be selected from clause 25.2 of IEC 60871-1.
- Year of manufacture
- Sound Level
- Other important details of Reactor

The rating plate shall be stainless steel to grade 316, and shall be located on the longer side of the Reactor or where it is easily visible.

7.10 Single Line Diagram, Protection Single Line Diagram and Control Drawing

The Tenderer shall be required to submit single line diagram for proposed connection of Capacitor Bank, Vacuum Switch and Reactor to existing 11kV indoor breaker. The Tenderer shall also be required to submit protection single line diagram with control drawing and proposed switching-mechanism. The Tenderer shall also include appropriate ratings and sizes of CT's and VT's as required for automatic

switching. The price for supply and installation of these CT's and VT's shall be provided in price breakdown.

7.11 Over-Voltage Protection and Surge Arrestors

The Tenderer shall propose and provide suitable surge arrestor type and connection arrangement in order to limit any - transferred internal and external over-voltages on the capacitor banks.

The Tenderer shall provide recommendations on under-voltage and over voltage protection for sustained under and over voltage conditions. EFL shall apply these settings to the protection relay at the point of connection.

7.12 Earthing and Lightning Protection

All equipment, except the phase and neutral connected capacitor bushing terminations, shall be effectively earthed to the extent that there is no safety hazard to operating personnel, to prevent accidental shorts by human error, flying objects or by rodents, and to prevent mechanical damage to the devices.

Prior to accessing the capacitor bank racks it must be visually identifiable that the earthing devices have been applied.

The Tenderer shall also provide earthing stirrups for the connection of the phases and neutral points to the portable earths to be applied by an operator standing at ground level using an operating stick.

All earthing points shall be connected to the substation earthing grid through an earth bar having the full fault current rating as indicated in the System Conditions. The earth bar shall have provisions for at least two connections to the substation earth grid at diagonally opposite sides of the capacitor bank.

The Tenderer shall prepare equipment earthing design with calculations and submit to EFL for review prior to its installation.

The Tenderer shall prepare lightning protection design with calculations and submit to EFL for review prior to its installation.

7.13 Ratings / Overload

The capacitor bank shall be designed to provide three phase reactive power for the each step at nominal voltage. The capacitor bank and capacitor units shall be capable of continuous operation at 135% of rated reactive power in accordance with IEEE std. 18.

In compliance with clause 27.2 of IEC 60871-1, the rated output voltage (UN) of the capacitor bank shall be not less than the maximum operating voltage of the network. However, the inductive elements such as detuning reactors connected in series with the capacitor bank, will increase the voltage at the capacitor terminals, and the rated voltage of the capacitors shall be increased accordingly. The rated voltage of the capacitor bank shall not be too high such that it limits the operating reactive power.

The capacitors shall be able to withstand the overloads specified in clauses 19 and 20 of IEC60871-1. Overloads are caused by system voltage fluctuations and the harmonic currents flowing through the capacitors.

The capacitor shall be designed for continuous operation at r.m.s. current which shall not be less than

143% of the rated current (IN) in order to take care of the combined effects of harmonics and over voltages described in clause 19 and 20 of IEC60871-1. For this purpose, the rated current (In) of the capacitor shall be calculated at the rated voltage when the capacitance is at maximum (that is, 1.1CN).

7.14 Discharge Capability

Each capacitor unit shall be provided with an internal discharge device so that the residual charge of the capacitor shall drop to 75V or less from initial maximum peak voltage of $\sqrt{2}$ times rated voltage (UN), within 10 minutes of being off line.

The internal discharge device shall not substitute the recommended practice of the manually discharging the residual stored charge before working on capacitors.

Suitable terminals for manual discharge of the capacitor shall be provided. All capacitor terminations shall be capable of being shorted to earth before handling.

7.15 Capacitor Bank Mounting Platform

A mounting platform, made of steel, shall be constructed on concrete pad for installation of capacitor banks with associated equipment such as Vacuum Switch and Reactor. The capacitor bank mounting platform shall include the following as a minimum:

- Steel frame
- Capacitor switches to isolate the capacitor bank(s) for repair and maintenance purposes
- Provision for earthing of star-point of capacitor bank
- Provision for connection of cables or overhead line jumpers to the capacitor switches

The Tenderer shall ensure that such platforms are made of steel and designed and constructed to withstand the cyclonic wind loading conditions prevalent in Fiji. The structural design of such mounting platforms shall have the approval of a chartered professional engineer registered with the Fiji Institute of Engineers, or an equivalent body recognized by the Fiji Institute of Engineers.

The Tenderer will be required to submit to capacitor bank installation layout plan for confirmation of space availability at site. It shall be the Tenderers responsibility to take measurements during tender site visit and submit bid offer accordingly. The outdoor capacitor bank mounting platform is approximately 35m away from existing control building. The control building houses existing 11kV switchboard. The tenderer shall make provision for installation of proposed control cubicle outside existing control building with outdoor enclosure for weather proofing.

8 CIVIL WORKS, INSTALLATION & OTHER SERVICES

8.1 Preliminary Works

The Tenderer shall collect for himself site levels, sub-soil data and other information to enable him to estimate the bearing capacity, foundation requirements, etc., for use in the preparation of the tender. After the award of the contract and handover of the site, the Tenderer must make his own site surveys to collect all the information to prepare layout drawings. The Tenderer shall survey the site to obtain details of above items. Site survey plan at a scale of 1: 500 shall be prepared, showing the survey results and the proposed layout of the new works. The plan shall be sent to the Employer's Representative for his approval. After completion of the work, the Contractor should do a complete detail survey of the substation including all the parts completed to the date of handing over. The Employer's Representative should be provided with 3 hard copies and a soft copy of the results.

Site Clearance

8.2.1 Removing/Shifting existing equipment, dismantling steel structures

Equipment and support steel structures, which are to be removed shall be removed carefully and handed over to the employer. Removing, dismantling, handling, transporting and handing over shall be done by the contractor as instructed by the Employer's Representative.

8.2.2 Demolishing & removing of existing Masonry/concrete structures

Unwanted foundations shall be demolished or up-rooted. The Contractor shall clear all areas required for the work. All unwanted materials, debris, etc. shall be removed from the employer's premises.

8.2 Control Cable Trenches & Ducts

The Tenderer is responsible for all civil works required for control cabling works between outdoor capacitor bank and control cubicle inside control building. The proposed route of control cable with appropriate sizes of conduits are to be approved by EFL prior to its installation.

8.3 Earthing Trenches & Reinstatement.

The Tenderer is responsible to carry out total trenching and reinstatement of earthing trench as per EFL approved earthing design and calculations.

8.4 Galvanized Steel Support Structures

8.4.1 General Requirements

All galvanized steel structures shall be provided under this Contract for supporting the insulators, capacitor bank, vacuum switch, reactor, underground cable, bus bars, earth wires. Support structures fitting shall be minimum of 120µm for C5M environment. The contractor will be required to provide certification to confirm on this requirement.

The structure shall include all necessary access ladders to give access to the various levels of equipment and shall incorporate all necessary earthing. The design and arrangement of supporting structures shall be subject to approval of EFL; such structures shall be rigid and self-bracing against all dead, wind, pull off and other applied loads. At or near ground level, all uprights shall be provided with holding down bolts. Steel sections forming the framework shall be heavily galvanized in accordance with the BS EN ISO 1461 1999 or AS/NZS 2312. The bolts and nuts shall be complying

with the ISO 898-1. Bolts and nuts shall be galvanized and fitted with spring washers. Taper washers are to be added where necessary. Threads of bolts shall be spun galvanized and the threads of nuts shall be oiled. All members shall be cut to jig and holes shall be drilled or punched to jig. Parts shall be carefully cut and holes accurately located so that when the members are in position the holes can be accurately aligned before being bolted up. Drifting of holes will not be permitted.

The design wind speed **85m/s**. The design calculations shall include the computation of stresses in all structural components and shall show how all loads are transferred to the foundations. The structures shall be designed to meet the maximum of the total forces calculated from the following loading.

- Dead weight
- Wind loading
- Short circuit force
- Loads arising during assembly and erection.

Recommended factors of safety for steel structures	1.5
Recommended factor of safety for foundations	1.5

Consideration shall be made in sizing members to eliminate excessive deflection or vibration during service. All structures shall be designed so that no failure or permanent distortion shall occur when tested with an applied force equal to 1.5 times the loading associated with the simultaneous applications of any of the load combinations.

The standards of workmanship, materials and design are to be equal to those laid down in the latest editions of BS 5950 or AS 4100. The Contractor shall make the following submittals to the Employer's Representative:

- Production mill sheet and quality control tests sheets for each delivery of structural steel.
 - Full details of the results of material tests.
 - Full details of steel types and types of nuts and bolts to be used.
 - Full details of erection procedures.
 - Full details of proposals for all main welds, arrangement of welded assemblies and welding procedure.
 - Approval of welders including all tests for welders
 - Full details of protection system to be used for steelwork.
 - Test results for paint thickness.
 - Results for structural deflections under test loads.
- The design of all structures shall be as specified and, in addition, is to ensure that in the event breakage of either one earth wire or one stay wire the factor of safety is not less than 1.5.

Samples of all materials shall be tested and copies of the test reports giving physical and chemical properties issued to the EFL for approval. These tests shall prove the compliance of the material for the purpose intended in accordance with the approved standard. Where tests are carried out by an independent laboratory, the source of origin of the material shall be stated and if different sources of supply are contemplated additional tests shall be carried out.

Shop connections shall generally be electric arc welded or bolted. Site connections shall be bolted as shown on the drawings unless specifically approved by EFL. Bracing connections shall develop forces not less than 50 percent of the effective capacity of the member. All connections shall have a minimum of 2 bolts per connections and the gusset plates shall have a minimum thickness of 10 mm. Fabrication and erection shall conform at all stages to the standard approved by EFL and allowance should be made for EFL to inspect the steelwork during fabrication and before shipment to site. Bolted construction shall be tested for dimensional accuracy before dispatch to site by the complete assembly of a frame or truss in the shop. Bolted connections shall be fabricated with due attention to the calculated mode of action of the joint and where an eccentricity cannot be avoided members must be adequate to resist the bending stresses induced. All steelwork shall be fabricated to the following tolerances below:

On length 1.3 mm

Twist and deviation from the required profile shall not exceed 1 in 1000.

Welding of structural steelworks shall be by an electric arc process. The procedure to be followed, plant and equipment to be used and the testing and inspecting to be applied, shall all be to the satisfaction of EFL and shall conform generally with BS 5135 or AS 1554 and with further details contained in the Specification. Electrodes for metal arc welding shall comply with BS EN 499 or AS/NZS 4857. Welded construction shall be carried out in workshops under approved conditions by experienced operators and where continuous supervision is exercised. Machine welding will be allowed where approved machines are in use, correctly controlled by qualified operators. Where the Employer's Representative approves site welding, this shall not adversely affect the efficiency of the welding and, where necessary, effective protection and other safeguards, as shall be agreed with the Employer's Representative.

The Tenderer shall provide all hoists, slings, cradles, ladders, scaffolds, plant and machinery required for the carrying out of the painting and in particular, he should pay special attention to his requirements for painting the structural steelwork on site. The suitability and capacity of all plant and equipment used for the carrying out of the painting shall be to the satisfaction of EFL. The Tenderer shall select a system of steelwork protection, which shall conform to the recommendations of BS 5493 or AS/NZS 2312 Protective coating of iron and steel structures against corrosion or equivalent standard. The selected system shall have a life to first maintenance of 20 years under the environmental conditions at the site, which shall for purposes of classification by BS 5493 or AS/NZS 2312.

8.4.2 Minimum Galvanizing Requirements

This article defines the minimum requirements for galvanizing as well as for surface cleaning and preparation for the protective coating of galvanized steel surfaces. All steel for outdoor and indoor use is to be galvanized and further painted if requested by the Employer's Representative. The galvanizing procedure shall be started only after having finished all chipping, trimming, fitting and bending. Also, all drilling punching, cutting and welding shall have been completed and all burns removed. All steel including bolts, nuts and washers, shall be galvanized at the manufacturer's premises by means of hot-dipping in accordance with internationally recognized standards such as:

Hot-Dip Galvanizing (HDG) – AS/NZS 4680

Minimum Coating Thickness:

For steel thickness ≥ 6 mm: 120 μ m (microns) average

For steel thickness < 6 mm: 100 μ m (microns) average

Surface Preparation:

Steel must be cleaned by abrasive blast cleaning (AS 1627.4) or pickling to remove mill scale, rust, and contaminants.

Galvanizing Process:

Full immersion in molten zinc (AS/NZS 4680).

Post-galvanizing inspection for uniformity, adhesion, and absence of defects.

Additional Protection (AS/NZS 2312 Recommendations for C5-M)

Duplex Coating (Galvanizing + Paint):

For enhanced corrosion resistance, a duplex system (HDG + suitable paint) is recommended.

Paint System: Epoxy or polyurethane-based coatings (AS/NZS 2312.2).

Sealing of Cut Edges & Welds:

After fabrication, any cut edges or welded areas should be re-protected with zinc-rich paint.

Material Selection (AS/NZS 3678 / AS/NZS 3679.1)

Steel should be suitable for galvanizing (avoid reactive steels like high-silicon content).

Inspection & Testing (AS/NZS 4680.1 Appendix D)

Coating thickness tested with a magnetic gauge (min 5 readings per batch).

Adhesion tested by knife or tape test.

No bare spots, excessive ash, or uncoated areas allowed.

Summary for C5-M (Very High Marine) Environment:

Requirement	Specification
Galvanizing Standard	AS/NZS 4680 (Hot-dip galvanizing)
Minimum Coating Thickness	≥6mm: 120µm / <6mm: 100µm
Additional Protection	Duplex coating (HDG + paint) recommended
Surface Preparation	Blast cleaning (AS 1627.4) or pickling
Post-Galvanizing Protection	Seal welds & cut edges with zinc-rich paint

8.4.3 Painting of Galvanized Outdoor Steel Structures

Where installed, after erection, on all galvanized steel the pre-primer (if any) is to be cleaned by use of a rotating wire brush and washed with fresh water. All galvanized steel must be painted with one layer of primer, one layer of intermediate coat and one layer of final coat with the paints specified in the Technical Data Sheets.

8.4.4 Transportation and Storage of Steelwork

All steelwork shall be transported, lifted and generally handled in a manner that does not affect the shape or surfaces of the section. Lifting slings shall be of nylon rope; chains and hooks shall not be used in contact with the steelwork. The position of lifting points used on sections shall be such that the stress induced in the sections does not exceed one half of the yield stress of the materials. Steelwork shall be stored in clean, dry conditions off the ground. Separate pieces of steelwork shall have spacer blocks between them.

8.4.5 Erection

The Tenderer must provide all temporary works, of any kind whatsoever, he shall deem necessary to ensure the correctness alignment and stability of the various frames and members. During erection the work shall be securely bolted or otherwise fastened and, if necessary, temporarily braced to provide safety for all erection stresses and conditions, including those due to erection equipment and its operation. No permanent bolting of high strength friction grip bolts shall be done until proper alignment has been obtained.

8.4.6 Inspection and Tests

The Tenderer shall supply to EFL details of all steelwork and accessories in order that inspection can be effected. Details shall include dates, times and places of manufacturing, rolling, fabricating, painting, galvanising and all other processes. The details shall be given to the EFL at least 7 days prior to such inspections taking place. All the tests shall be carried out by the Tenderer. The Tenderer shall prepare test sample to suit the appropriate testing methods all tests and inspection results shall be submitted to EFL within 24 hours of the test completion. Inspection and Testing of Welds to be inspected shall not be painted or otherwise obscured until they have been inspected.

8.4.7 Inspection and Testing of Paint

Tests shall be carried out to the appropriate sections of BS 3900 or AS 1580. Tests for final dry film

thickness (DFT) shall be carried out over 10% of the painted area. Over such test areas, readings shall be taken on a grid 200-mm square and recorded. The Tenderer shall carry out tests, which are requested by EFL as specified in relevant British Standards.

8.4.8 Testing of Welding Operators

Only welding operators who satisfy the appropriate tests shall be employed on welding. Should an operator fail in the first test, two further tests shall be undertaken immediately and to qualify the operator must satisfactorily pass both these tests.

8.4.9 Responsibility and Guarantees

EFL shall have access at all times for inspection of the work and all pertinent materials during preparation and progress of the work. Should any work or material be found to be defective or not in compliance with EFL, correction or replacement shall be done by the Tenderer at his own cost.

8.4.10 Factory Acceptance Testing

Any Steel Structures which are procured out of Fiji will require Factory Acceptance Testing before shipment. The Tenderer will be required to arrange for two (2) x EFL Engineers Factory visit including all associated cost.

8.5 Concrete Pad for Steel Structure Mounting

The concrete pad for the mounting of steel structure shall be designed based on equipment selection and respective weights. The concrete pad drawing with design calculations and appropriate sizing of reinforcement steel bars shall be submitted to EFL for approval prior to its construction at site.

8.5.1 Concrete

The Tenderer shall submit not less than 3 weeks before the commencement of manufacture of preliminary trial design mix for 30Mpa Concrete strength. The following information to EFL in respect of each grade of concrete that will be supplied by an established and reputable ready mix concrete supplier.

- (1) Grade of concrete
- (2) Title of particular trial mix.
- (3) The grading of the aggregates.
- (4) The ratio by weight of all the constituents of the concrete.
- (5) The expected compacting factor and slump.
- (6) Full details of the proposed site quality control.
- (7) Full details of the proposed laboratory for testing.

The Tenderer shall also confirm his proposed testing regime and acceptance criteria for the Preliminary Trial Mixes. If the proposals not be approved by EFL, and then the Tenderer shall comply with the paragraph on preliminary test cylinders and the two following paragraphs. At least four weeks before commencing any Concreting in the Works, the Tenderer shall make trial mixes using samples of aggregates and cements typical of those to be used. If possible, the Concreting plant and the means of transport to be employed in the Works shall be used to make the trial mixes and to transport them a representative distance. A clean dry mixer shall be used to make the trial mixes and the first batch shall be discarded. Preliminary test Cylinders shall be taken from the proposed mixes as follows:

For each grade, a set of 6 cylinders shall be made from each of 3 consecutive batches. Three from each set of six shall be tested at an age of seven days and three at an age of 28 days. The cylinders shall be made, cured, stored, transported and tested in compression in accordance with AS/NZS 1012.8.1, AS/NZS 1012.9, AS/NZS 1012.14 or AS 1012. The test shall be carried out in a laboratory shall be approved by EFL. If it is proposed to use an admixture in the mix then for each grade of

concrete a batch shall be made with a double dose of the additive. For each of these batches 3 cylinders shall be made and one tested at 7 days and 2 at 28 days to determine the likely effect of error in dispensing.

The trial design mix proportions shall be approved if the average strength of a set of 9 cylinders tested at 28 days exceeded the specified characteristic compressive strength by current margin less 3.5 N/mm². The results of the seven-day cylinder tests shall be used to give an indication for future use of the strengths likely to be achieved at 28 days. They shall not be used to satisfy the 28 days preliminary test cylinder strength requirements.

The Tenderer shall inform the EFL of his intention to carry out such tests and the time and place of the tests at least 24 hours before they take place. Neither the mix proportions nor the source of supply of materials shall be altered without the prior approval of EFL except that the Tenderer shall adjust the proportions of the mix as required to take account of permitted variations in the materials. Such approval shall be subject to the execution, to the EFL satisfaction, of trial mix procedures set out herein.

Curing of Concrete, ready-mixed, shall comply to the requirements of AS/NZS 1012.8.1. Site mixing of concrete is not allowed.

For the 30Mpa Concrete the acceptable characteristic compressive strength is 36.5Mpa. Any Test result below 26Mpa will be automatic total rejection of works.

8.6 Chain Link Fence and Gate

Chain link fences shall be constructed of galvanized steel wire, and shall be of such manufacture that when any one segment is cut, remaining segments within the pattern retain their rigidity. The bottom of the fence shall be fixed down with staples to a continuous concrete sill (in 2 layers of block work), in accordance with BS 1722, Part 10 or AS 1725. All mesh shall be of galvanized steel wire of 3.15 mm diameter, with a length of side not exceeding 50 mm. Line wires shall be of galvanized steel wire of the same gauge to adequately support the mesh rigidly. Line wire shall be provided at the top and bottom of the mesh and at two evenly spaced intermediate levels. The line wires shall be strained tightly by eyebolt strainers or winders at each straining post and secured to intermediate posts of stirrup wires passed through holes in the posts. The top wire shall be doubled, Mesh and line wires shall comply with BS 4102 or AS 2423. Chain link mesh shall be strained between straining posts by means of stretcher bars and tied to line wires. Straining posts and struts shall be of Galvanized steel to the same standard as above. The posts shall be set in concrete in the ground. The posts shall have cranked tops set at 45° to the posts, to which shall be attached three strands of galvanized barbed wire to BS 4102 or AS 2423. Barbed wires shall be strained between straining posts with eyebolts and fixed to intermediate posts with stirrup wires. Droppers shall be fitted at the centre of each Bay of the fence to prevent the wires being bunched together. Intermediate posts shall be provided at centres not exceeding 3 meters. Corner posts and struts shall be provided at all ends, corners, and changes in direction and adjacent to gateposts. All fence fittings shall be galvanized. All galvanized post shall have PVC caps installed.

9 TESTING

The Tenderer shall be responsible for carrying out tests to demonstrate the equipment and its components supplied, complies with the technical requirements in this specification. All routine, type and special tests shall be conducted with the equipment completely assembled in the factory with all support structures installed and operational. Type tests shall be carried out on the first unit under the contract unless otherwise agreed by EFL.

The type, special and routine tests shall be carried out on the equipment and its components in accordance with this specification, prior to approval being granted for use by EFL.

All type tests shall be carried out by a testing authority holding accreditation.

All type test reports shall be accompanied by copies of the accreditation certificate(s) issued to the testing laboratory. The accreditation certificate(s) shall be valid for the relevant test(s) and for the duration of the test(s).

Type tests shall be less than five years old. Type tests beyond this limit may be acceptable at the discretion of EFL if sufficient information can be provided to show that the manufacturing process, raw materials, design and quality control processes have not significantly changed since the original test date.

All sample and routine tests may be conducted at the manufacturing facility's test laboratory on the condition that sufficient evidence is provided to EFL to demonstrate the testing facility's capability to perform the specified tests.

As a minimum, the following information shall be provided:

- qualifications/experience of the testing staff;
- test procedures for all sample/routine tests;
- testing facility quality control procedures; and,
- test instrument calibration certificates/procedures.

All documentation submitted (including reports, tests, testing procedures/policies, calibration certificates and the like) written in any language other than English shall not be accepted by EFL.

All test results shall be included in the maintenance manuals with a note indicating that the test results relate to the original or agreed nominated unit.

One copy of all test results shall be provided to EFL nominated project manager within one week of the completion of the tests for approval, and shall include a cover page that lists all the tests and a statement indicating that all tests have passed including guaranteed values. The equipment shall only be shipped from the factory after the test reports have been approved by EFL. Should there be a discrepancy or a test failure, this shall be noted on the cover sheet.

9.1 Type Tests

9.1.1 Capacitor Unit, Vacuum Switch and Reactor

The following type and special tests shall be carried out as indicated below:

No.	Description of Test	Test Method Reference
1.	Thermal Stability Test	IEC 60871.1 Clause 13
2.	Capacitor Losses (tan delta)	IEC 60871.1 Clause 14
3.	AC voltage test between terminals and container	IEC 60871.1 Clause 15.1
4.	Lightning Impulse Test between terminals and container	IEC 60871.1 Clause 15.2
5.	Over-voltage test	IEC 60871.1 Clause 16
6.	Short Circuit Discharge test	IEC 60871.1 Clause 17
7.	Disconnecting test on internal fuses	IEC 60871.4 Clause 5.2
8.	Endurance Test (Special Test)	IEC 60871.1 Clause 17 & IEC 60871.2
9.	RIV Test	IEC 62271-1 Clause 6.9.1

9.2 Routine Tests

9.2.1 Capacitor Unit, Vacuum Switch and Reactor

Applicable routine tests in accordance with the applicable standards shall be carried out on each component of the equipment. These tests shall be included in the Factory Acceptance Tests (FAT) for the equipment and submitted to EFL for approval. The equipment shall not be delivered unless the FAT reports are approved:

No.	Description of Test	Test Method Reference
1.	Capacitance measurement test	IEC 60871.1 Clause 7
2.	Capacitor losses (tan delta)	IEC 60871.1 Clause 8
3.	Voltage test between terminals	IEC 60871.1 Clause 9
4.	AC voltage test between terminals and container	IEC 60871.1 Clause 10
5.	Test on internal discharge device	IEC 60871.1 Clause 11
6.	Sealing Test	IEC 60871.1 Clause 12
7.	Discharge test on internal fuses	IEC 60871.4 Clause 5.1.2

9.3 Acceptance Tests

The Tenderer shall outline the acceptance tests which will be required to be performed on the capacitor bank units when it is installed. EFL's minimum requirements for acceptance tests are as follows:

- Capacitor unit capacitance measurement
- Power frequency tests (high voltage test)
- Insulation resistance tests
- Doctor tests on all joints
- Partial discharge tests
- Functionality test of control system for Automatic Switching subject to voltage profile

9.4 Witnessing of Tests

The Tenderer shall make allowance for up to two (2) EFL's Engineers to witness the type tests which shall be requested to be performed. All costs for the witnessing of such type tests shall be borne by the Tenderer, including airfares, accommodation, meals etc. The Tenderer shall also make allowance for witnessing of routine tests by two (2) EFL Engineers.

Where applicable, the Tenderer shall give EFL not less than four (4) weeks' notice of when each and every type test will be carried out.

9.5 Test Certificates

Two (2) certified copies of all test results shall be supplied to EFL. Electronic copies shall also be submitted.

All test certificates shall include the manufacturer's serial number. On allocation, the corresponding EFL order number must be added to the certificate, or attached to the test report.

10 TECHNICAL LITERATURE – OPERATIONS AND MAINTENANCE MANUALS

Tenderers shall furnish all technical literature, including catalogues, test certificates etc. in support of plant and equipment offered by him with the tender. The successful tenderer is to interface existing and new equipment drawings and a set of original drawings.

Successful contractor shall forward 6 copies of all operations and maintenance manuals, spare parts catalogues, detailed schematic and wiring diagrams and all other documents required for satisfactory operation and maintenance of plant. The originals of the drawings in AutoCAD format are required to be handed over. As built drawings are required to be furnished in 6 copies before the works are taken over as per Clause 5.6 & 5.7 of FIDIC Document (Conditions of Contract for Design – Build And Turnkey) edition 1.

During the design and manufacture stage the Tenderer shall submit all design calculations, design drawings, technical submissions at each stage of design or manufacture for the approval of EFL.

The manuals shall include the following sections:

10.1 Plant Specification and Description

The Plant Specification and Description Section shall include the specification and description of each plant item and system.

10.2 Installation and Commissioning

The Installation and Commissioning Section shall include step-by-step procedures for the unloading, unpacking, transport, handling, assembly, erection, adjustment, alignment, preparation for service and testing of the plant.

10.3 Operation

The Operation Section shall describe in detail the procedures for the preparation into service, setting, adjusting, checking before and during operation, routine testing and operating of the plant to be supplied. It shall provide complete information on operating limitations, allowable rates of temperature change, allowable temperature differentials and any other information required by operating staff to ensure the safe and efficient operation of the plant.

10.4 Maintenance

The Maintenance Section shall contain sufficient detail to enable maintenance personnel to maintain the plant in good working condition and plant maintenance from time to time. It shall describe and include pictorial representation of step-by-step procedures for dismantling, reassembly, alignment, replacement and adjustment of all components of the plant. This Section shall also include standards of workmanship, tolerances, air gaps, electrical resistance values, limits of wear, periodic adjustments, material specifications including special procedures (e.g. heat treatment), weights of large items, details and uses of special tools, test equipment, jigs, gauges and tightening torque values for bolts.

The Tenderer shall set down recommendations for preventive or condition based maintenance, including frequency of inspection and guidance in locating and rectifying faults and condition monitoring or diagnostic testing which may be performed on a regular basis.

Similarly lubrication routines shall be specified including locations, recommended frequency and recommended type of lubricants.

11 TRAINING

Training shall be provided before commencing the installation and commissioning of the relevant equipment at site. The Tenderer shall therefore submit the training program for each category along with the installation/erection and commissioning program. The Tenderer shall also be required to prepare Safe Operating Procedure for capacitor bank.

12 DESIGN REVIEWS

The Tenderer shall allow for online meetings for review and approval of switch type Capacitor Bank and associated equipment's, single line diagram, protection single line diagram and control drawing prior to manufacture of major equipment.

13 RELIABILITY

13.1 Service Life

Tenderers are required to comment on the reliability of the equipment and the performance of the materials offered for a service life of 45 years under the specified system and environmental conditions.

13.2 Evidence in Support of Reliability

Such comments will include evidence in support of the reliability and performance claimed including information on Failure Mode and Effect Analysis.

14 ENVIRONMENTAL CONSIDERATIONS

Tenderers are required to comment on the environmental soundness of the design and material used in the manufacture of the items offered. In particular, comments should address such issues as recyclability and disposal at end of service life.

Tenderers are required to provide with the tender, EMF levels at capacitor bank. Such EMF levels are required at a point midway along each side, and diagonally out from each corner, at a distance of 1m above and beyond the base.

15 PACKAGING AND MARKING

The packaging of items by the Tenderer must ensure that they are capable of being delivered undamaged giving due consideration to the quantity, distance of transportation and the preferred method of handling at each location.

The Tenderer shall take all necessary precautions to ensure safe handling of all capacitor banks and associated accessories supplied.

16 QUALITY REQUIREMENTS

Tenderers are required to submit evidence that the design, manufacture and testing of the capacitor banks are in accordance with AS/NZS 9001-2016 or ISO 9001-2015. Documentary evidence shall be provided concerning the level of Quality System Certification associated with the Tenderer and or manufacturer. This documentation shall include the Capability Statement associated with the Quality System Certification.

17 PRODUCT WARRANTY PERIOD

The Tenderer is required to provide the warranty period as part of the proposal. A minimum warranty period of twenty-four (24) months from time of dispatch from factory shall be provided.

18 RECOMMENDED SPARES

The tenderer is required to submit list of recommended spares for capacitor bank, associated equipment's and control system for automatic switching. The Tenderer is also required to fill in price for recommended spares in price schedule.

19 SCHEDULE OF PRICES

19.1 Notes of Schedules

The Schedules are intended to provide the Employer with essential supplementary information in an organized format. Examples of more commonly used Schedules are given herein. Others may be devised and added in accordance with the requirements of the Instructions to Bidders.

All the Schedules are essential for bid evaluation and some in contract execution; they should all be incorporated in the Contract, and appropriate changes introduced with the approval of the Employer or its representative.

The schedules are to be completed and submitted as part of the Technical Proposal and Price Proposal in accordance with the Instructions to Bidders Clause 13, Documents Comprising the Bid.

19.2 Schedule of Prices & Conditions of Payment

19.2.1 Contract Price

The Contract Price is comprehensive in that, in consideration of the Contractor meeting all obligations, conditions and liabilities under the Contract, including the Contractor's allowance for the cost of supply of all labour, materials, plant, supervision required to complete the Contract Works, overheads and profit, subject only such adjustment as is provided for the Contract.

19.2.2 Basis of Schedules

Descriptions of various items contained in the Schedule of Prices are intended to be a complete definition of the scope of the Contract Works, for which reference shall be made to the Specification, Drawings, Basis of Payments and other Contract Documents. The items descriptions on the Schedule of Prices shall be used only for the purpose of calculating progress payments and for valuing variations.

19.2.3 Payment Terms

1. All payments shall be due and payable by EFL in accordance with the payments terms detailed below.
2. The payments shall be made on completion of milestones as identified and agreed by both the Employer's Representative and the Contractor.
3. The payments will be made based on the following schedule:
 - a. ninety percent (90%) of the total DDU to Site amount shall be paid on submission of receipt of invoice and documents. Documentation shall include as a minimum a bill of landing, a sea way bill, an airway bill, a railway consignment note, a road consignment note, insurance certificate as appropriate for the method of transportation undertaken.
 - b. five percent (5%) of the total DDU to Site amount shall be paid upon issue of Completion Certificate.
4. • five percent (5%) of the total DDU to Site amount shall be paid upon completion of retention period.
5. Payments to be made under this contract fall into two categories:
 - i. i] payments for work carried out off-shore and hence not subject to GST or VAT.
 - ii. ii] payments for work carried out within Fiji (i.e. on-shore), and hence
6. shall be subject to Fiji tax, legislation including the VAT Decree 1991 and its subsequent amendments.

7. Off - Shore Work

All invoices issued for off-shore work pursuant to this Contract shall be expressed in the foreign currency stated in Appendix to Bid, and will be issued using Contractor's overseas office letterhead. No GST or VAT shall be included in the invoice.

8. The Employer shall pay the invoice amount in foreign currency to each overseas bank account nominated by Contractor within 30 days of acceptance of the invoice.

9. On - Shore Work

All invoices issued for on-shore work pursuant to this Contract shall be expressed in Fiji Dollar currency, obtained by converting any foreign currency amounts to Fiji dollars using the corresponding foreign exchange rate prevailing on the date of the invoice. Any Value added Tax (VAT) amount component at the prevailing VAT rate shall be added to indicate the VAT inclusive price (VIP).

10. If the Employer disputes any portion of the amount claimed in an invoice submitted by the Contractor or by its Fijian registered entity, the Employer shall notify the Contractor in writing of the reasons for disputing the amount and the Employer shall pay that portion of the amount in the invoice that is not in dispute.
11. If any payment due to the Contractor or its Fijian registered entity through a valid invoice submitted to the Employer is not received by the Contractor within 30 working days from the date of receipt by the Employer of any undisputed invoice, the Employer shall pay interest as from the due date at the Reserve Bank of Fiji Lending Rate per annum accruing daily.
12. The Contractor hereby agrees that payments made by the Employer in accordance with this Agreement to the Contractor's Fijian registered entity shall be proper consideration deemed to be received by the Contractor.
13. All matters relating to taxation such as income tax, withholding tax, PAYE and other tax issues shall be the responsibility of the Contractor and its Fijian registered entity. Similarly any superannuation related issues such as FNPF liabilities (where applicable) shall be the responsibility of the Contractor and its Fijian registered entity.

19.3 Schedules of Rates & Prices

19.3.1 Notes on Schedules of Rates and Prices

1. The Schedules are divided into six separate sections as follows:
 - Price Schedule of Main Items
 - Alternative Offers
 - Recommended Tools & Spare Parts
 - Summary of Prices
 - Bidders Tools & Equipment
 - Rate of Variations
2. The quantities shown in these schedules are estimates only.
3. The Schedules do not generally give a full description of the plant and equipment to be supplied and the services to be performed under each item. Bidders shall be deemed to have read the Employer's Requirements and other section of the bidding documents and reviewed the Drawings to ascertain the full scope of the requirements included in each item prior to filling in the rates and prices. The entered rate and prices shall be deemed to include for the full scope as aforesaid including overheads and profit.
4. Bid prices shall be quoted in the manner indicated and in the currencies specified in the Instructions to Bidders in the bidding documents.
For each item, bidder shall complete each appropriate column in the respective Schedules, giving the price breakdown as indicated in the Schedules.
Prices given in the Schedules against each item shall be for the scope covered by that item as detailed in the Employer's Requirements, Drawings or elsewhere in the bidding documents.
5. Items left blank will be deemed to have been included in other items.
6. These schedules are intended primarily to provide information for bid evaluation but not intended to be used for the evaluation of work done for the purpose of interim payment. They may however, be used as a reference for the adjustment of the Schedule of Payment should the need arise.
7. These schedules can also be used as a basis to value variations of work done under the Proposal Sum.

19.4 Drawings, Design and Documentation

F/C – Foreign Currency
FJD – Fijian Dollars

Item No.	Description	Estimated		Rate		Total Price	
		Qty	Unit	F/C	FJD	F/C	FJD
1	<i>1.2MVAR Capacitor Bank</i>						
1.1	<u>ELECTRICAL WORKS</u>						
1.1.1	Design and Liaison of Works	1	LS				
1.1.2	Drawings and Documentation required for Electrical works	1	LS				
1.2	<u>CIVIL WORKS</u>						
1.2.1	Design and Liaison of Works	1	LS				
1.2.2	Drawings and Documentation required for Civil works	1	LS				
TOTAL (Transfer to Grand Summary)							

4.2	All DC power and control cables from capacitor bank to point of connection (existing control building) and terminations.	As required								
5	<u>CIVIL AND ARCHITECTURAL WORKS</u>									
5.1	Concrete foundation with appropriate sizes of steel reinforcements for platform mounting with site preparation works.	As required								
5.2	Material and accessories for Steel Platform for Capacitor Bank Mounting as proposed in General Arrangement drawing and in accordance to technical requirement in Clause 8 of this tender.	As required								
5.3	Chain link fence with gate and associated materials.	As required								
6	<u>MANDATORY SPARES</u>									
6.1	Item 1	As required								
6.2	Item 2	As required								
6.2	Etc									
TOTAL OF EQUIPMENT SUPPLY										

4.2	All DC power and control cables from capacitor bank to point of connection (existing control building) and terminations.	As required								
5	<u>CIVIL AND ARCHITECTURAL WORKS</u>									
5.1	Concrete foundation with appropriate sizes of steel reinforcements for platform mounting with site preparation works.	As required								
5.2	Material and accessories for Steel Platform for Capacitor Bank Mounting as proposed in General Arrangement drawing and in accordance to technical requirement in Clause 8 of this tender.	As required								
5.3	Chain link fence with gate and associated materials.	As required								
TOTAL OF CIVIL WORKS, INSTALLATION AND OTHER SERVICES										

19.7 Grand Summary

ITEM	DESCRIPTION	TOTAL PRICE	
		F/C	FJD
1.0	Design, drawings and documentation		
2.0	Plant and equipment including mandatory spares		
3.0	Civil Works, installation and other services		
GRAND TOTAL			

20 INFORMATION TO BE SUPPLIED BY THE TENDERER

20.1 Documentation to be supplied with the tender

To enable EFL to fully evaluate the capacitor bank(s) offered, (in addition to the completed Specification Requirement and Guaranteed Performance schedules) the Tenderer will submit the following information with their tender:

- Required Technical Schedules and Schedule of Prices.
- List showing similar equipment supplied to or on order for other utilities.
- Typical arrangement drawings and full details of the dimensions of the capacitor bank, vacuum switch and reactor.
- Overall general arrangement of switched-type outdoor capacitor bank with vacuum switch and reactor. This is required to confirm footprint required at site for actual implementation.
- Type test certificates.
- Short circuit test details for equipment of similar design and rating.
- Sample inspection and test plans for the capacitor banks, vacuum switch and reactor.
- Typical installation and maintenance manuals.
- End of service life disposal method.
- Full details of the protective coatings offered.
- Details of mounting structures and the footprint required.
- A list of all departures of the tender from this specification.
- Evidence of quality management systems.
- Evidence of financial ability.
- Origin of materials used in manufacture of the capacitor bank.
- Detailed procedure for receiving, handling, lifting and storage.
- Names and resumes of key team members who will be assigned to work with EFL upon successful award of contract (if Tenderer is successful).
- Works Programme.

Tenderers may be asked to provide additional information during tender assessment period or following award of contract.

TENDER CHECKLIST

The Bidders must ensure that the details and documentation mention below must be submitted as part of their tender Bid

Tender Number: _____

Tender Name _____

Full Company / Business Name: _____
(Attach copy of Registration Certificate)

Director/Owner(s): _____

Postal Address: _____

Phone Contact: _____

Fax Number: _____

Email address: _____

Office Location: _____

TIN Number: _____
(Attach copy of the VAT/TIN Registration Certificate - Local Bidders Only) (Mandatory)

FNPF Employer Registration Number: **__(For Local Bidders only) (Mandatory)**

Provide a copy of Valid FNPF Compliance Certificate (Mandatory- Local Bidders only)

Provide a copy of Valid FRCS (Tax) Compliance Certificate (Mandatory Local Bidders only)

Provide a copy of Valid FNU Compliance Certificate (Mandatory Local Bidders only)

Contact Person: _____

I declare that all the above information is correct. Name: _____

Position: _____

Sign: _____ Date: _____

TENDER SUBMISSION - INSTRUCTION TO BIDDERS

Bidders are requested to upload electronic copies via Tender Link by registering their interest at: <https://www.tenderlink.com/efl>

EFL will not accept any hard copy submission to be dropped in the tender box at EFL Head Office in Suva.

This tender closes at 4.00pm (1600hrs) on Wednesday 25th February, 2026.

For further information or clarification please contact our Supply Chain Office on phone **(+679) 3224360** or **(+679) 9992400** or email us on tenders@efl.com.fj

The bidders must ensure that their bid is inclusive of all Taxes payable under Fiji Income Tax Act. Bidders are to clearly state the percentage of VAT that is applicable to the bid prices.

The lowest bid will not necessarily be accepted as the successful bid.

The Tender Bids particularly the “Price” must be typed and not hand written.

Any request for the extension of the closing date must be addressed to EFL in writing five (5) working days prior to the tender closing date.

Tender Submission via email or fax will not be accepted.

APPENDIX A: SPECIFICATION REQUIREMENT

Items and Units	Required	Supplied
1.0 Capacitor Bank		
1.1 Reactive Power Output (MVAR)	1.2MVAR	Manufacturer to state
1.2 Capacitor Voltage Rating (kV)	11kV	Manufacturer to state
1.3 Frequency (Hz)	50Hz	Manufacturer to state
1.4 Test Requirements <ul style="list-style-type: none"> • Routine Tests • Type Test 	As per specs	Manufacturer to provide certificates and reports.
1.5 Maximum system voltage (kV)	12kV	Manufacturer to state
1.6 Maximum continuous operating voltage (kVrms)	As per IEC 60099-4	Manufacturer to state
1.7 Dimension's		Manufacturer to state
1.8 Insulation Level		Manufacturer to state
1.9 Number of capacitors (no)		Manufacturer to state
1.10 Control Voltage	110V	Manufacturer to state
1.11 Temperature range (degrees Celsius)		Manufacturer to state
2.0 Capacitor Units		
2.1 Type	All film	Manufacturer to state
2.2 Bushing Type		
2.3 Rated current unit capacitor (A)	Specify	Manufacturer to state
2.4 Rated Voltage unit capacitor (kV)	Specify	Manufacturer to state
2.5 Insulation level of each capacitor bank		Manufacturer to state
2.6 Discharge Time	75V in less than 10 mins	Manufacturer to state
2.7 Continuous over current	1.3x In (rated current)	Manufacturer to state
2.8 Continuous over voltage	1.1x Vn (rated voltage)	Manufacturer to state
2.9 Container Material and Thickness		Manufacturer to specify
2.10 Creepage Distance	50mm/kV (open rack)	Manufacturer to state
2.11 Bushing Material		Manufacturer to specify
2.12 Dielectric material		Manufacturer to specify
2.13 Connection	3 phase	Manufacturer to state
2.14 Peak withstand current (kA)	As per spec	Manufacturer to specify
2.15 Rated lightning impulse (kV-peak)		Manufacturer to specify
2.16 Rated short circuit current (kA)	25kA	Manufacturer to specify
2.17 Pollution level (mm/kV, p-p)		Manufacturer to specify
3.0 Fuse – Cutouts		
3.1 Rated Voltage (kV)	11 kV	Manufacturer to state
3.2 Highest Voltage (kV)	12 kV	Manufacturer to state
3.3 Rated Continuous current (A)		Manufacturer to state
3.4 Insulation level		Manufacturer to specify
3.5 Total creepage distance		Manufacturer to specify
3.6 Mounting angle		Manufacturer to specify
3.7 Dry impulse withstand (4.8/50us) voltage (positive and negative polarity (peak))		Manufacturer to specify

i) Across the isolating distance of the fuse base		Manufacturer to state
ii) To earth and between poles		Manufacturer to state
3.8 Wet 1 minute power frequency withstand voltage (rms)		Manufacturer to specify
i) Across isolating distance of the fuse		Manufacturer to state
ii) To earth and between poles.		Manufacturer to state
4.0 Vacuum Switch		
4.1 Brand		Manufacturer to state
4.2 Bushing Type		Manufacturer to state
4.3 Rated current (A)	Specify	Manufacturer to state
4.4 Rated Voltage (kV)	Specify	Manufacturer to state
4.5 Insulation level of each vacuum switch		Manufacturer to state
4.6 Capacitive Switching Capability		Manufacturer to state
4.7 Continuous over current	1.3x In (rated current)	Manufacturer to state
4.8 Continuous over voltage	1.1x Vn (rated voltage)	Manufacturer to state
4.9 Creepage Distance	50mm/kV (open rack)	Manufacturer to state
4.10 Container Material and Thickness		Manufacturer to specify
4.11 Connection	3 phase	Manufacturer to state
4.12 Peak withstand current (kA)	As per spec	Manufacturer to state
4.13 Rated lightning impulse (kV-peak)		Manufacturer to state
4.14 Rated short circuit current (kA)	25kA	Manufacturer to state
4.15 Pollution level (mm/kV, p-p)		Manufacturer to state
4.16 Other important details as required		Manufacturer to state
5.0 Reactor		
5.1 Type & Brand		Manufacturer to state
5.2 Bushing Type		Manufacturer to state
5.3 Rated current (A)		Manufacturer to state
5.4 Rated Voltage (kV)		Manufacturer to state
5.5 Capacitive switching withstand capability		Manufacturer to state
5.6 Continuous over current	1.3x In (rated current)	Manufacturer to state
5.7 Continuous over voltage	1.1x Vn (rated voltage)	Manufacturer to state
5.8 Container Material and Thickness		Manufacturer to specify
5.9 Creepage Distance	50mm/kV (open rack)	Manufacturer to state
5.10 Connection	3 phase	Manufacturer to state
5.11 Peak withstand current (kA)		Manufacturer to specify
5.12 Rated lightning impulse (kV-peak)		Manufacturer to specify
5.13 Rated short circuit current (kA)	As per spec	Manufacturer to specify
5.14 Pollution level (mm/kV, p-p)		Manufacturer to specify
5.15 Other important details as required		Manufacturer to specify

APPENDIX B: OTHER REQUIREMENTS

The Tenderer is required to fill in other requirements as per tender requirements.

No.	Particulars	Tenderers Response
1.	The capacitor bank(s) shall not in any way amplify or contribute to increasing the harmonic distortion at the point of connection. The Supplier shall submit evidence to substantiate this - 6.4 Harmonics	
2.	The capacitor banks supplied shall conform to all the current requirements of: <ul style="list-style-type: none"> • IEC60871.1 for capacitor units, and • all relevant Australian and IEC Standards and this specification. 	
3.	Supply of any special tools - 7.1 General	
4.	All materials shall be of a type and quality that will give a normal life expectancy of 45 years - 7.1 General (provide evidence)	
5.	The internal fuses shall comply with IEC 60593 standards - 7.2 Capacitor Bank	
6.	The capacitor units shall be compactly designed in size and weight to be conveniently mounted to pole or substation structure. The housing shall have a rugged and reliable construction for outdoor mounting. Detailed drawings of construction are required - 7.2 Capacitor Bank	
7.	Shall provide continuously 1.35 times the rated output - 7.2 Capacitor Bank	
8.	The impregnate shall be of a hydrocarbon type fluid characterized by high electrical strength and adequate physical and chemical properties and shall be non-PCB - 7.2 Capacitor Bank	
9.	capacitor banks/units protection shall meet all the requirements of IEC 60871-3 - 7.5 Capacitor Protection	
10.	The Tenderer must provide the following in his bid for tender evaluation: - - 7.5 Capacitor Protection <ol style="list-style-type: none"> a) Calculation of constrains subjected to capacitor units. b) The fuse time current coordination curve. c) Recommendation of fusing to provide a satisfactory probability against case rupture. 	
11.	The Tenderer shall propose and provide suitable surge arrester type and connection arrangement in order to limit any - transferred internal and external over-voltages on the capacitor banks - 7.11 Over-Voltage Protection and Surge Arrestors	
12.	The Tenderer shall provide recommendations on under-voltage and over voltage protection for sustained under and over voltage conditions. EFL shall apply these settings to the protection relay at the point of connection - 7.11 Over-Voltage Protection and Surge Arrestors	
13.	All equipment, except the phase and neutral connected capacitor bushing terminations, shall be effectively earthed and must be visually identifiable that the earthing devices have been applied - 7.12 Earthing	
14.	Provide earthing stirrups for the connection of the phases and neutral points to the portable earths to be applied by an operator standing at ground level using an operating stick - 7.12 Earthing	
15.	Earth bar having the full fault current rating as indicated in the System Conditions. The earth bar shall have provisions for at least two connections to the substation earth grid at diagonally opposite sides of the capacitor bank - 7.12 Earthing	
16.	The tenderer shall prepare equipment earthing & lightning protection design with calculations and submit to EFL for review prior to its installation - 7.12 Earthing	
17.	In compliance with clause 27.2 of IEC 60871-1, the rated output voltage (UN) of the capacitor bank shall be not less than the maximum operating voltage of the network. However, the inductive elements such as detuning reactors connected in series with the capacitor bank, will increase the voltage at the capacitor terminals, and the rated voltage of the capacitors shall be increased accordingly. The rated voltage of the capacitor bank shall not be too high such that it limits the operating reactive power - 7.13 Ratings / Overload	
18.	The capacitors shall be able to withstand the overloads specified in clauses 19 and 20 of IEC60871-1 - 7.13 Ratings / Overload	
19.	The capacitor shall be designed for continuous operation at r.m.s. current which shall not be less than 143% of the rated current (IN) in order to take care of the combined effects of harmonics and over voltages described in clause 19 and 20 of IEC60871-1	
20.	Suitable terminals for manual discharge of the capacitor shall be provided. All capacitor terminations shall be capable of being shorted to earth before handling - 7.14 Discharge Capability	
21.	The capacitor bank mounting platform shall include the following as a minimum - 7.15	

	<p>Capacitor Bank Mounting Platform</p> <ul style="list-style-type: none"> • Steel frame • Capacitor switches to isolate the capacitor bank(s) for repair and maintenance purposes • Provision for earthing of star-point of capacitor bank • Provision for connection of cables or overhead line jumpers to the capacitor switches 	
22.	Tenderers are required to comment on the environmental soundness of the design and material used in the manufacture of the items offered. In particular, comments should address such issues as recyclability and disposal at end of service life - 14 Environmental Considerations	
23.	Tenderers are required to provide with the tender, EMF levels at capacitor bank. Such EMF levels are required at a point midway along each side, and diagonally out from each corner, at a distance of 1m above and beyond the base - 14 Environmental Considerations	
24.	Tenderers are required to submit evidence that the design, manufacture and testing of the capacitor banks are in accordance with AS/NZS 9001-2016 or ISO 9001-2015. Documentary evidence shall be provided concerning the level of Quality System Certification associated with the Tenderer and or manufacturer. This documentation shall include the Capability Statement associated with the Quality System Certification - 16 Quality Requirements	
25.	The Bidder is required to provide the warranty period as part of the proposal. A minimum warranty period of twenty-four (24) months from time of dispatch from factory shall be provided - 17 Product Warranty Period	
26.	<p>20.1 Documentation to be supplied with the tender:</p> <ul style="list-style-type: none"> • List showing similar equipment supplied to or on order for other utilities • Typical arrangement drawings and full details of the dimensions of the capacitor bank • Type test certificates • Short circuit test details for equipment of similar design and rating • Sample inspection and test plans for the capacitor banks • Typical installation and maintenance manuals • End of service life disposal method • Full details of the protective coatings offered • Details of mounting structures and the footprint required • A list of all departures of the tender from this specification • Evidence of quality management systems • Evidence of financial ability • Origin of materials used in manufacture of the capacitor bank • Detailed procedure for receiving, handling, lifting and storage • Names and resumes of key team members who will be assigned to work with EFL upon successful award of contract (if Tenderer is successful). 	

APPENDIX C: WORK PROGRAMME

The Tenderer is required to state the commencement and completion timeline for the following tentative work programme. The contractor is to also submit a Gantt chart for the programme outlining the activity, duration, start date, completion date, milestones, resources, etc.

	Component	Start	Finish
	Design of capacitor bank and approval by employer	Week 1	
	Manufacture of capacitor bank, vacuum switch, and reactor and associated materials.		
	Testing at Manufactures premises (witness testing)		
	Shipping of plant and equipment		
	Installation of capacitor bank (may be carried out in stages)		
	Completion of wiring for controls and protection equipment		
	Inspection and pre-commissioning tests		
	Testing, commissioning and handover		

Note that the items in the work programme are the responsibility the Tenderer. All site tests to be carried out as per the contract are an absolute minimum. Additional tests may be required by EFL.

APPENDIX D: DEPARTURE FROM SPECIFICATIONS

The Tenderer shall nominate the Clause or relevant section of the tender specification and describe the departure.

Tender Specification Referenceⁱ	Departure

ⁱ Where possible, the Tenderer shall refer to the specific clause of the tender specification.

APPENDIX E: SCHEDULE OF SUPPLEMENTARY INFORMATION

1 Tenderer's Statement of Experience

The Tenderer shall state hereunder a brief resume of his experience in the design, manufacturer supply, installation and commissioning of 11kV and 33kV outdoor capacitor bank stating the employer's name, contact person, telephone number and fax number. Failure to complete this schedule with full satisfactory details and documentary proof will render the offer liable to rejection.

Country		
System Voltage kV		
Type of Construction		
Purchaser		
Consultant		
Size of Capacitor Bank		
Contract Award Date		
Contractual Completion Date		
Actual Completion Date		
Contract Value		

2 Schedule of Financial Information

The Tenderer shall state hereunder:

- (a) The full name, business address, nationality and type of organization.
- (b) The full name and business address of any Fijian agent.
- (c) The date of the Tenderer's formation.
- (d) The Tenderer's capitalization and total sales over the preceding three fiscal years.
- (e) Details of supply and erection contracts of a similar nature undertaken in the previous five years, giving details of at least three contracts stating the location, purchaser, dates of commencement and completion and value of the contract in the total foreign currency equivalent.
- (f) Details of any contracts on which the Tenderer has defaulted or on which liquidated damages have been applied in the previous five years giving location, purchaser, value of the contract, and nature of the default or penalty.
- (g) Name and address of two banks and the name and address of an independent accountant, all of whom shall be authorized to provide promptly on request any information about the financial status of the Tenderer which is required by the EFL on the understanding that such information will be kept confidential and will only be used to assess the financial ability of the Tenderer to undertake the Contract.

3 Personnel

The tenderer shall provide a details all the personnel that would be involved in the execution of the project - from the design stage till the completion stage. Relevant details such as years of experience shall be provided.

4 CONTRACTOR HEALTH & SAFETY PLAN

The bidder shall complete the following sub-sections to provide details in relation to the Health and Safety plans for the project.

CONTRACT DETAILS

Contractor Name: _____
Contractor Address: _____
Contractor Representative: _____
Contract Description: _____
Location of Works: _____
Timing of Works (approximate): Start Date: _____ End Date: _____

RESPONSIBILITIES

Name	Position Held	Safety Responsibilities	Contact Number (Direct)

EMERGENCY CONTACT DETAILS

Contact	Name	Position	Contact Number (Direct)
First Contact			
Second Contact			
Third Contact			
Fourth Contact			

SCOPE & TASK DETAILS

List Major Tasks

RISK ASSESSMENT

Risk assessment is a fundamental tool in management of risk. It involves the identification of hazards and control measures. Describe how you plan to carry out this process for this particular application contract.

--

SAFE WORK PROCEDURES

After completing the risk assessment, you must compile a safe system of work describing how you plan to control the hazards you have identified. Complete the following section outlining how you will ensure that all employees and subcontractors understand the Safe Work Procedures (SWP). Also attach copies of the relevant SWP.

--

PERSONAL PROTECTIVE EQUIPMENT

Where risk assessment identifies the need for personal protective equipment (PPE), then PPE must be made available. List down below the PPE you will require for this project.

ACCESSING SITE/TIMES OF WORK

If work is going to be carried out at EFL premises, then it is important to determine when you will be accessing the Site. You may need to sign a PASS and sign in and out. This will avoid conflicts with other activities which may be continuing on site during contract works. Describe below your site access requirements.

FENCING & SEPARATION OF WORK

In order to protect our employees as well as general members of the public, the work areas should, so far as is possible, be physically isolated with barriers like bollards, cones, tapes, netting, etc. Describe below how you will fence or separate your work.

SIGNS AND WARNINGS

Sufficient signs should be erected or placed so that adequate warning is afforded around the worksite. Describe the kinds of notices you will be putting up and places where you will be putting this.

GENERAL STORAGE & DISPOSAL OF WASTE

Describe below what waste you anticipate producing and how you plan to store and/or dispose off waste. You must take into account the nature of the waste e.g. hazardous/flammable.

FIRST AID & INJURY MANAGEMENT

A first aid program for contractors is outlined in EFL Safety Manual. Please describe below any additional first aid needs and specific Injury management process for this contract.

EMERGENCY PROCEDURES

Identify specific emergency procedures or equipment required for the contract.

INCIDENT REPORTING & INVESTIGATION

Describe how incidents will be reported and investigated during the contract.

SPECIALISED WORK OR LICENSING

List any special licences required for the contract.

TRAINING & INDUCTION REQUIREMENTS

Training and inductions for contractors are to be completed in accordance with the EFL Training requirements. List any training required for the contract works in relation to safety, for example safe procedure training and attach training certificates:

SAFETY MONITORING

List any ongoing inspections, hazards management or incident reporting or investigation processes to be used during the works, if relevant.

Describe below your site access requirements.

SUBCONTRACTOR MANAGEMENT

Complete the attached Subcontractor List detailing the subcontractors to be used and the details of the subcontractor management:

Sub-Contractor Name	Sub-Contractor Representative Name	Description of Work	Date of Local Induction

5 PLANT & EQUIPMENT REGISTER

Complete the following table:

Type	Registration Include: Design, Design No. Item, Item No.	Purpose (Use on Site)	Inspection Date and Frequency	Inspected by

Contractor Signature: _____

Date: _____

6 CONTRACTOR CHEMICAL REGISTER

Complete the following table:

Product Name	Hazard	Controls Required	Location	Quantity

1 Contractor Signature: _____

2 Date: _____

APPENDIX E: Korovou Power Station Layout and Existing Capacitor Bank in Operation



Figure 1: EFL Korovou Power Station Layout

APPENDIX F: Typical SLD for Capacitor Bank with Vacuum Switch, Reactor and Neutral CT.

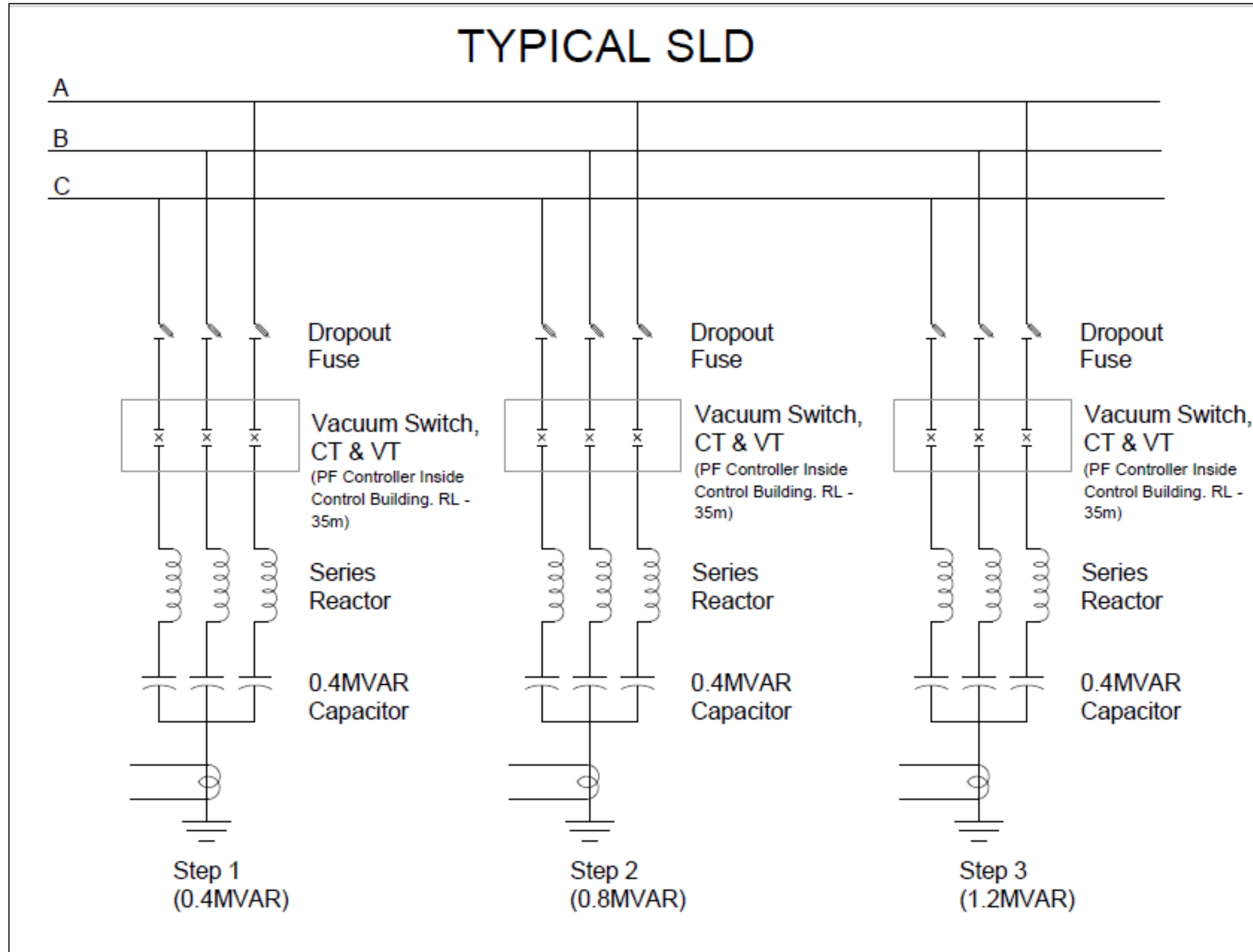

Figure 2: Typical Single Line Diagram

TENDER CHECKLIST

The Bidders must ensure that the details and documentation mention below must be submitted as part of their tender Bid

Tender Number _____

Tender Name _____

1. Full Company / Business Name: _____

(Attach copy of Registration Certificate)

2. Director/Owner(s): _____

3. Postal Address: _____

4. Phone Contact: _____

5. Fax Number: _____

6. Email address: _____

7. Office Location: _____

8. TIN Number: _____

(Attach copy of the VAT/TIN Registration Certificate - Local Bidders Only (Mandatory))

9. FNPF Employer Registration Number: _____ **(For Local Bidders only) (Mandatory)**

10. **Provide a copy of Valid FNPF Compliance Certificate (Mandatory- Local Bidders only)**

11. **Provide a copy of Valid FRCS (Tax) Compliance Certificate (Mandatory Local Bidders only)**

12. **Provide a copy of Valid FNU Compliance Certificate (Mandatory Local Bidders only)**

13. Contact Person: _____

I declare that all the above information is correct.

Name: _____

Position: _____

Sign: _____

Date: _____

Tender submission

Bidders are requested to upload electronic copies via Tender Link by registering their interest at: <https://www.tenderlink.com/efl>

EFL will not accept any hard copy submission to be dropped in the tender box at EFL Head Office in Suva.

This tender closes at 4.00pm (1600hrs) on Wednesday 25th February, 2026.

For further information or clarification please contact our Supply Chain Office on phone **(+679) 3224360** or **(+679) 9992400** or email us on tenders@efl.com.fj

The bidders must ensure that their bid is inclusive of all Taxes payable under Fiji Income Tax Act. Bidders are to clearly state the percentage of VAT that is applicable to the bid prices.

The lowest bid will not necessarily be accepted as the successful bid.

The Tender Bids particularly the “Price” must be typed and not hand written.

Any request for the extension of the closing date must be addressed to EFL in writing three (3) working days prior to the tender closing date.

Tender Submission via email or fax will not be accepted.