

**NOTE**

- FITTINGS ARE INDICATIVE ONLY - CONTRACTOR SHOULD REVIEW FITTINGS SUPPLIED AGAINST ARRANGEMENT SHOWN TO CONFIRM SUITABILITY PRIOR TO ORDERING.
- FAULT RATING OF ASSEMBLY TO MATCH OR EXCEED FAULT RATING OF OPGW.
- ALL BOLTED FITTINGS TO COMPLY WITH AS1154 AND TO BE SUPPLIED WITH SPLIT PIN.
- ALL NUTS & SPLIT PINS ARE TO BE ORIENTATED IN THE SAME DIRECTION OR TOWARDS GROUND LEVEL WHERE POSSIBLE.
- THE INSULATED EARTHWIRE, CLEATS, AND LUGS ARE TO BE SPECIFIED, SUPPLIED AND INSTALLED AS PART OF THE SUBSTATION CONTRACT.

QTY.	ITEM	DESCRIPTION	REFERENCE/REMARKS
1	1	TENSION SET, TO SUIT $\phi$ 7.6mm OPGW WEDGE TYPE, COMPLETE W/ RETENTION RODS	REFER AS1154
1	2	INSULATOR, DISC, TOUGHENED GLASS, 146mm C/C, 16mm, 70kN	REFER AS1154/AS62271.301
2	3	SHACKLE, 16mm, 70kN F/L, COMPLETE WITH M16 BOLT ASSEMBLY	REFER AS1154
1	4	BOLT ASSEMBLY, M12x35, GALVANISED	REFER AS1111
1	5	SOCKET/TONGUE, 16mm, 70kN F/L	REFER AS1154
1	6	BALL/EYE, 16mm, 70kN	REFER AS1154

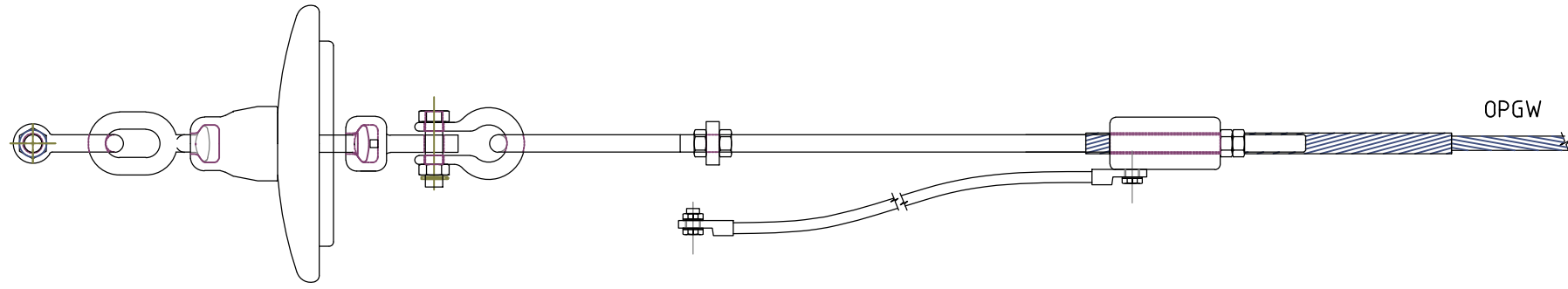

**PLAN**

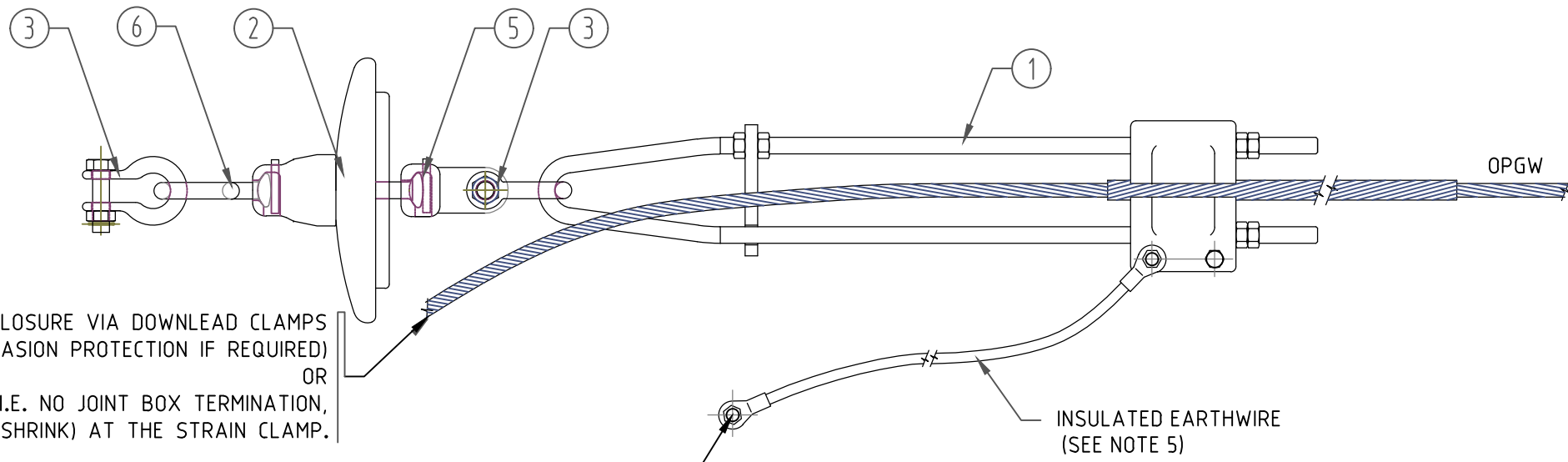

**SIDE VIEW**

TO OPGW JOINT ENCLOSURE VIA DOWNLEAD CLAMPS  
FIXED WITH A-FRAME MOUNTS (FIT ABRASION PROTECTION IF REQUIRED)  
OR  
IF OPGW IS USED AS OHEW, I.E. NO JOINT BOX TERMINATION,  
THE OPGW SHALL BE CUT AND CAPPED (HEAT SHRINK) AT THE STRAIN CLAMP.

LUGS AND BOLT ARE INDICATIVE ONLY  
(SEE NOTE 5)

INSULATED EARTHWIRE  
(SEE NOTE 5)

ENTURA IS A BUSINESS OF HYDRO-ELECTRIC CORPORATION ABN 48 072 377 158

DRAWN	AJD
CHECKED	
DESIGNED	
CHECKED	
APPROVED	
DATE	
CLIENT APP'D	
DATE	

**entura**  
 WE OWN. WE OPERATE. WE CONSULT.  
 89 Cambridge Park Drive, Cambridge,  
 Tasmania, 7170, AUSTRALIA  
 Ph: 03 6245 4500 Fax: 03 6245 4550  
[www.entura.com.au](http://www.entura.com.au)  
 © COPYRIGHT 2012

CLIENT	SOLOMON POWER	ENGAGEMENT No:	E307765
TITLE	LUNGA - HONIARA 33kV TRANSMISSION LINE OPGW STRAIN (TO SUIT $\phi$ 7.6mm OPGW) ASSEMBLY - INSULATED		
DRG No.	SP-LH-AS-004	SHT.	002
		REV.	0 A3