

Waste Heat to Power The Baseload Renewable You Already Have

July 2018

Waste Heat to Power

Highlights

- Founded in 2005
- Patented & Patent-Pending Technology
- 68 Operational Machines
- Acquired by BITZER in 2016

ElectraTherm's Power+ Generator™

Commercial Release August 2011

- Up to 110 kW_e Power Output
- More than 900,000 Hours Run Time



THIS IS SMART POWER®

BITZER INTEGRATION



BITZER is the world's largest independent manufacturer of refrigeration compressors

- BITZER 2017 Revenue: ~\$720M Euros
- Employees Worldwide: 3,400

June 2017: ElectraTherm headquarters relocated to the BITZER production facility in Flowery Branch, Georgia.



GLOBAL INSTALLATIONS



Austria
Czech Republic
France
Germany
Italy
Japan
Romania
Slovakia
United Kingdom
United States



DIVERSE APPLICATIONS

HOT WATER is the fuel (85-122°C/185-251 °F)

- Biomass Boilers
- Reciprocating Engines
- Methane Utilization
- Geothermal/Oil & Gas Wells
- Process Heat



FLEET PROFILE BY GEOGRAPHY

(Operational is the running Fleet, In Process is pending commissioning, production and backlog)

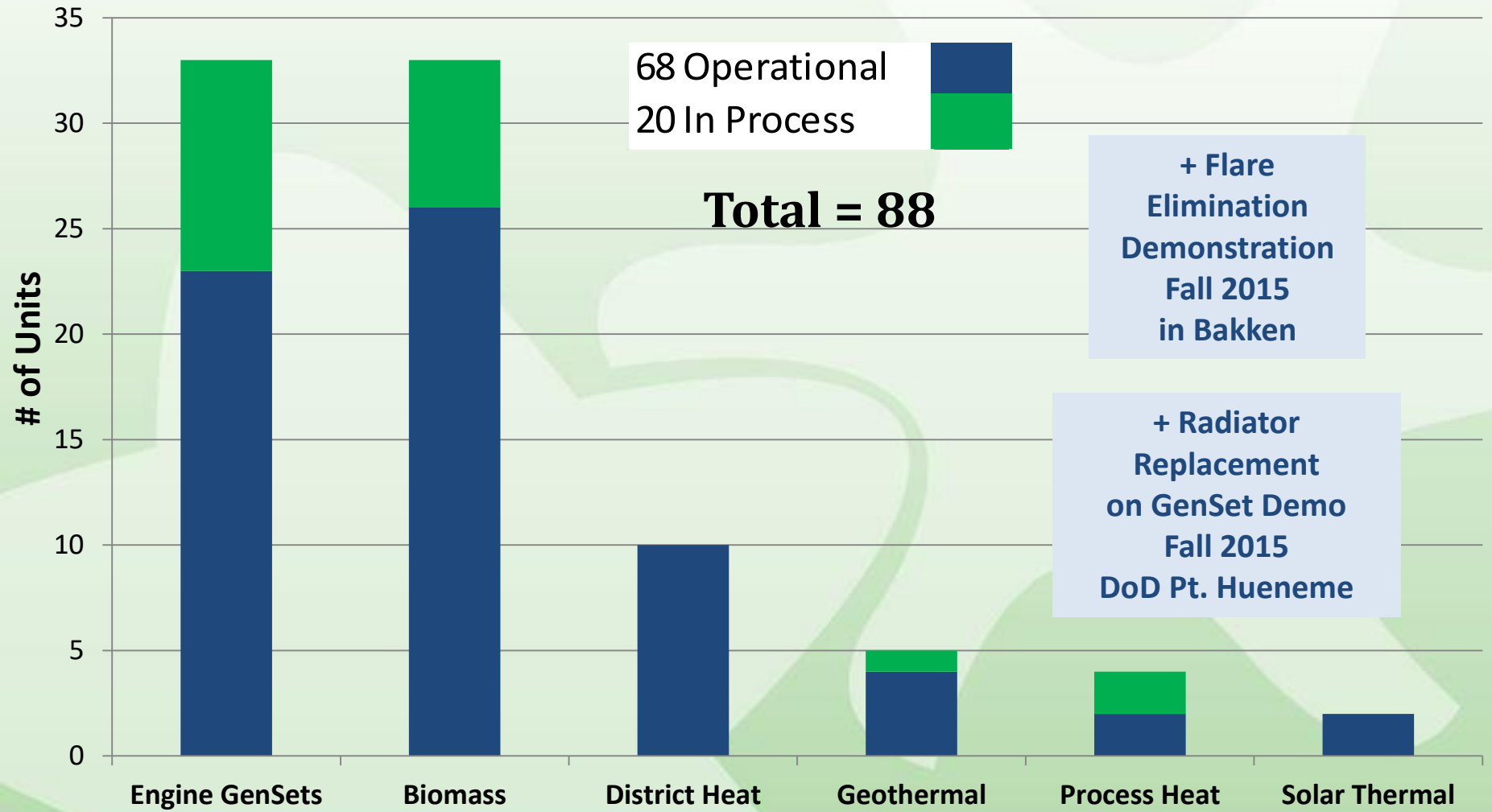

LEVELIZED COST OF ELECTRICITY GENERATION

20 year CapEx + Fuel + OpEx
\$ Per Kilowatt Hour

POWER+ Units

- ✓ No Fuel
- ✓ No Combustion

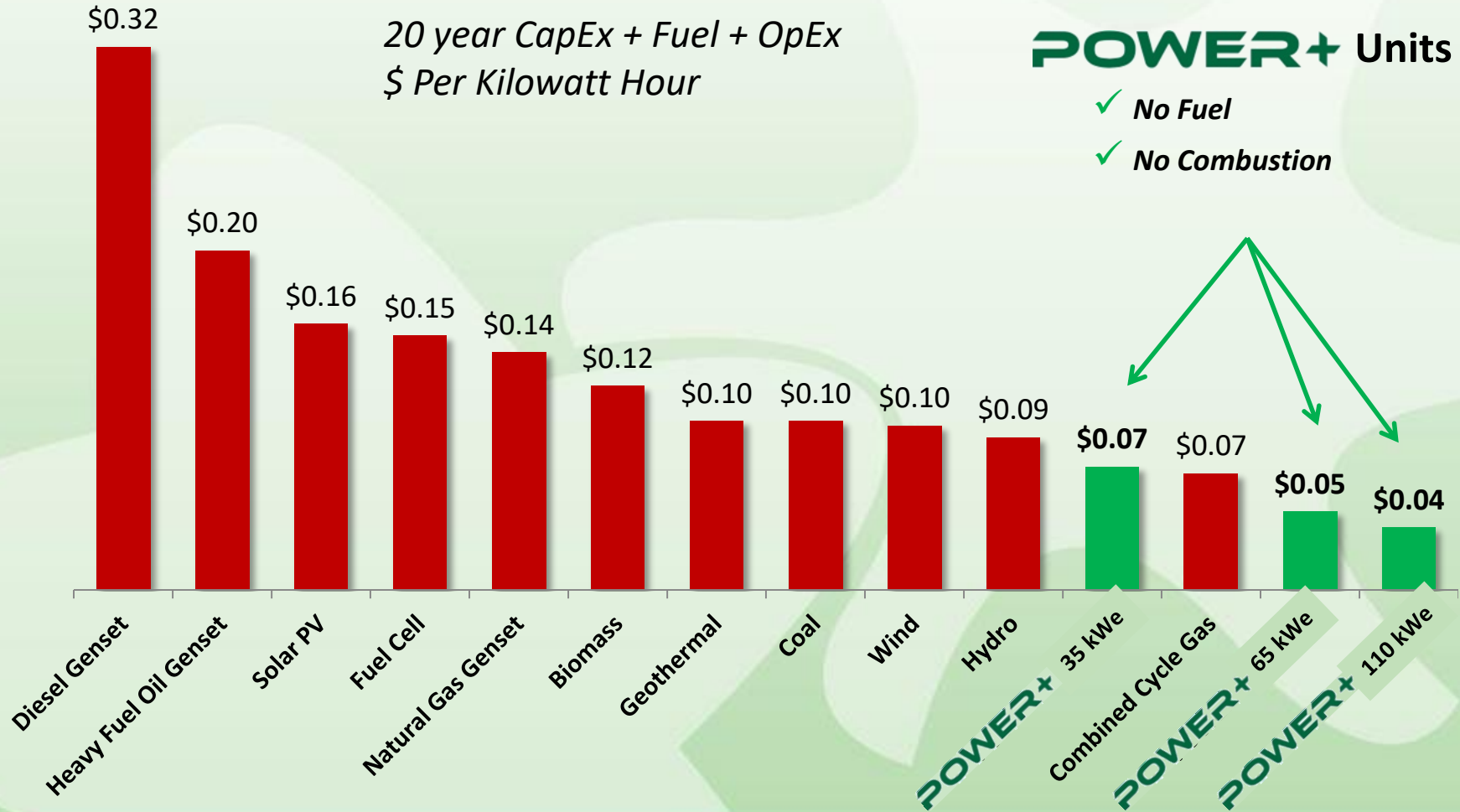

Waste Heat From Stationary Engines

Engines used for prime power ,landfill gas, waste water treatment plants, CHP

Ex. Jenbacher 316 (834 kWe)

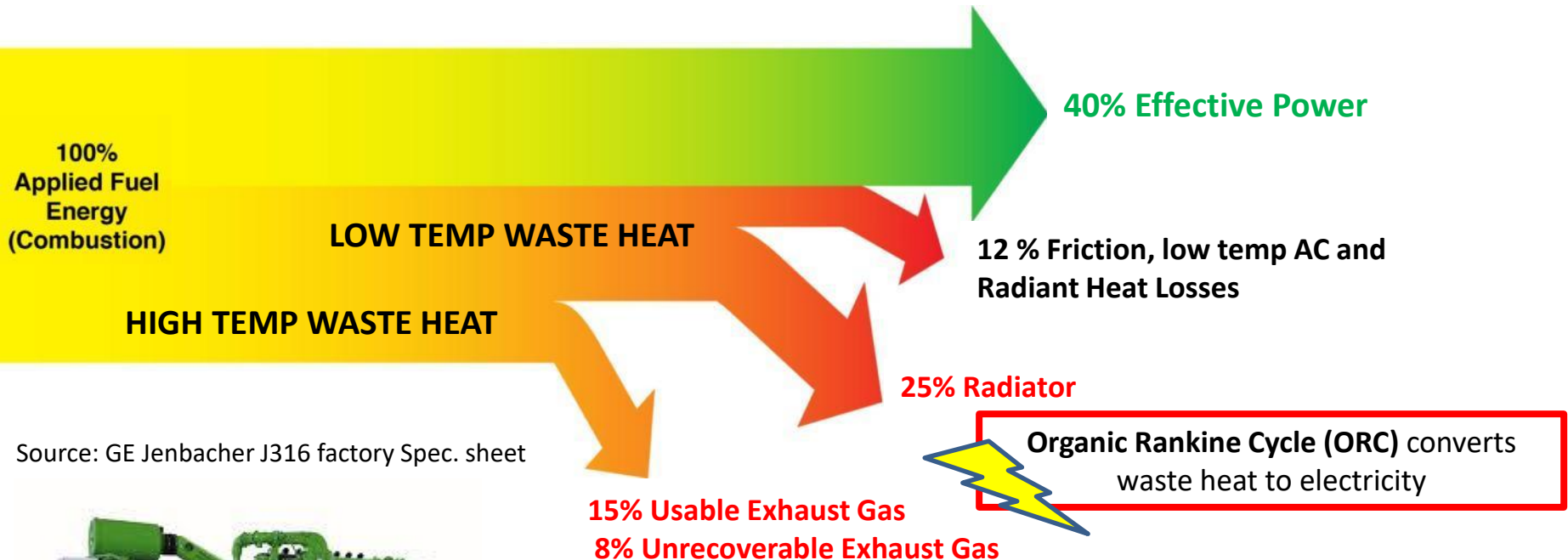

Source: GE Jenbacher J316 factory Spec. sheet



**100,000+ Stationary Engines
Installed Worldwide
.5-2 MW, Continuous Duty**

Development of the Radiator with a Payback

Benefits:

- Complete Engine Radiator Replacement
- Engine Cooling Independent of ORC Operation
- ORC Provides Hot Ambient Cooling Benefits
- 10% - 12%+ Improved Fuel Efficiency
- Easily Transportable
- Limited Site Construction
- Payback 2-3 years (diesel)

*1.1 MW Cummins Genset and
Exhaust Gas Heat Exchanger*



POWER+ ORC

*Combined Engine
and ORC Radiator*

“The Radiator with a Payback”

Video at <https://youtu.be/fca0faX8R84>

BIOGAS FLAGSHIP SITES



Trechwitz, Germany



Trebova, Czech Rep.



Bratcice, Czech Rep.



Inning, Austria



Drahodobudice, Czech Rep.



Slapanov, Czech Rep.



Kosova Hora, Czech Rep.



Grabsleben, Germany



Kaarsen, Germany



Valovice, Czech Rep.



Straznice, Czech Rep.



Lapouyade, France

REMOTE DIESEL FLAGSHIP SITE



20,000+ hours of run time

**Dutch
Harbor,
Unalaska**

Referral and introductions upon request

Engine/ORC combination running only on the jacket water

Engine with ORC

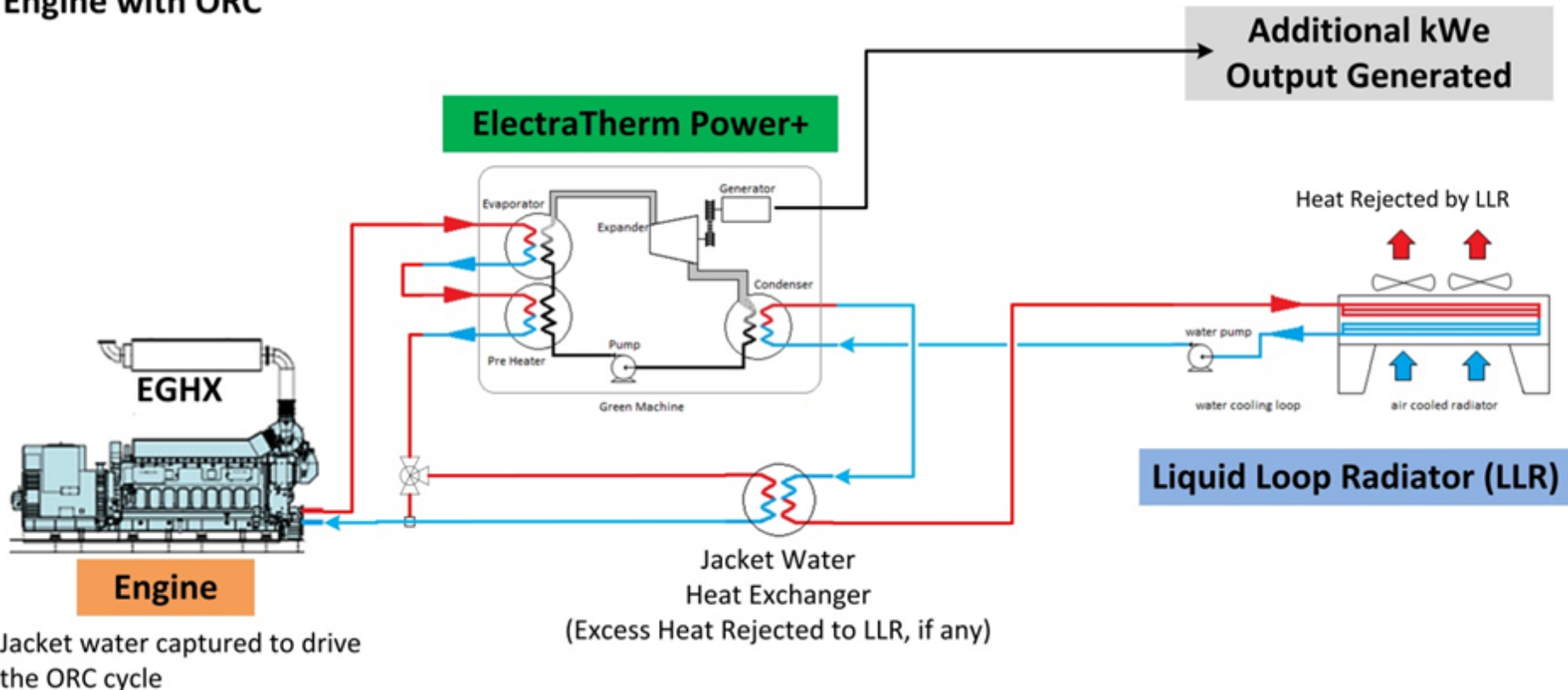

Engine/ORC combination running in a dual heat stream configuration

Engine with ORC Dual Heat Stream

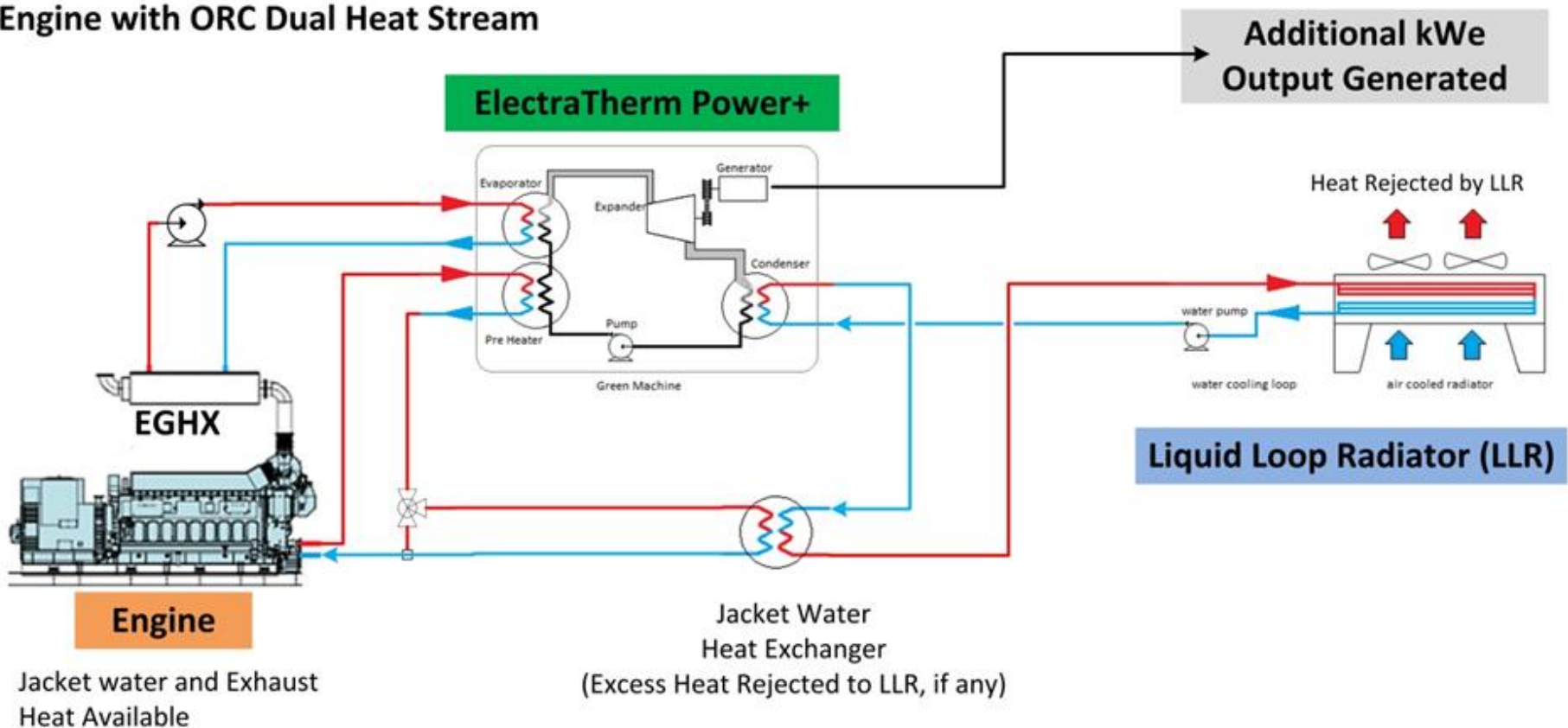

Diesel & Gas Turbine Worldwide Magazine Article Features ElectraTherm



POWER GENERATION

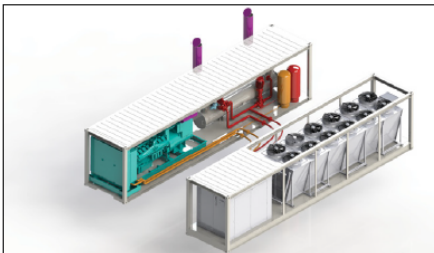

The DOD-funded ORC integration and replacement project that will deploy later this year is comprised of two 40 ft. (12 m) ISO shipping containers.

Utilizing Waste Heat For Power

Advanced engine cooling with economic payback; DOD project demonstrates up to 12% increase in fuel efficiency

Continuous duty gen-sets provide base-load power generation in diverse applications around the globe. However, high fuel costs and engine maintenance are pain points felt by operators. A low-maintenance path to significant fuel savings and lower emissions is what the U.S. Department of Defense (DOD) had in mind when they approached ElectraTherm to integrate the company's Green Machine waste heat to power (WHP) generator with a 1.1 MW Cummins KTA-50 generator.

ElectraTherm's primary market is waste heat from stationary internal combustion engines. Typical sites for these engines include prime power production in remote areas, island and developing nations, biogas gen-sets including landfill and waste water treatment plants, natural gas compression stations and renewable biofuels. With the typical engine running at about 35% efficiency, there is considerable waste heat between the jacket water and the exhaust that ElectraTherm converts into emissions-free/fuel-free electricity.

ElectraTherm specializes in small-scale, distributed power generation from waste heat, utilizing Organic Rankine Cycle (ORC) and proprietary technologies to generate power from low temperature heat ranging from 77° to 116°C. The company's WHP technology converts various sources of heat into power, including internal combustion engines, small geothermal, biomass, concentrated solar and process heat. To date, ElectraTherm said it has deployed 42 units worldwide, with a cumulative 250 000 operating hours and over 97% availability.

ElectraTherm's Green Machine generator operates using a closed-loop ORC, where hot water is the fuel. Hot water from the engine enters a heat exchanger to excite (pressurize) the non-flammable, nontoxic working fluid, driving the twin-screw expander and generator to create electricity. The company said its twin-screw expander is unique in its configuration, lubrication and specifications, but the core technology is based on decades of proven compressor technology.

The twin-screw expander has a rotational speed of 1800 to 4900

r/min, considerably less than turboexpanders, according to ElectraTherm. Unlike high-speed turboexpanders, screw expanders are robust units that tolerate "wet" dual-phase flow.

"This allows a very robust and cost-effective design for the Green Machine that can tolerate perturbations in both temperature and flow with turn down ratios of 6:1 available on demand," said John Fox, CEO of ElectraTherm, Inc. "This is particularly advantageous in low temperature waste heat streams such as engine jacket water. Our Green Machine design is simplified and eliminates lubrication reservoirs, oil coolers, pumps and land filters, creating a simple, robust and efficient system with fewer parasitic loads and maintenance requirements."

The Green Machine acts as the engine's radiator, so the engine-driven radiator fans can actually be disconnected (or eliminated completely for a new installation), allowing more work to be performed by the engine to generate additional electricity. In effect, the engine's waste heat becomes a source of cost savings by displacing the radiator's capital cost and parasitic load.

Between the DOD project and the machines currently running in the field, ElectraTherm said it increases fuel efficiency up to 12%, depending on engine size and configuration, and site conditions while featuring simple installation, mobility and low maintenance.

There are multiple benefits to integrating an ORC heat to power generator with an engine gen-set: the additional electrical output from the conversion of the waste heat to electricity with no additional fuel consumption or emissions, and the reduction or elimination of the parasitic load from the engine cooling fans. In hot climates or seasonally high ambient conditions, which often coincide with peak demand, the engine's derate can be reduced due to the added cooling effect of the ORC, thereby increasing the power output of the engine. "The additional benefits from

POWER+ FAMILY OF PRODUCTS

Model	Product
-------	---------

POWER+ 6500
Up to 110kW

40'x8'x8' / 12.2x2.4x2.4 m
Packaged Solution



POWER+ 4400
Up to 65kW



7'x7'x7' / 2.1x2.1x2.1 m
Standalone

POWER+ 4200
Up to 35kW

40'x8'x8' / 12.2x2.4x2.4 m
Packaged Solution



ElectraTherm offers 3 output levels packaged with cooling circuit or standalone

Economics running 95% of the time



		\$	Single Currency
	\$ x 1 = \$	CONFIDENTIAL	
	1.00	Payback Estimator	
Series 6000 Power+ Generator	\$ 410,000	Power+ Generator	
Water plumbing	\$ 20,000	Plumbing, piping, connections, valves and assembly	
Electrical components and hookup	\$ 15,000	Electrical conduit, wiring, and component installation	
Exhaust gas heat exchanger	\$ 125,000	Exhaust gas heat exchanger, pump, and plumbing if required	
Radiator with a payback option	\$ 15,000	Additional HX / Pump / BOP	
misc expense	\$ 10,000	misc.	
Commissioning and startup of P+	\$ 8,000	Technicians with travel expenses for two days	
Shipping Power+ Generator	\$ 25,000	Estimated shipping of P+ to site	
Estimated Total Capital Expenditure (CapEx)	\$ 628,000	Estimated Total CapEx for this Project	
CapEx including Incentives	\$ 628,000	CapEx including Incentives	
Total value of power per kWh	\$ 0.28	Average value of kWh produced	
Percentage of uptime hours (100% max/8760hrs)	95%	95% uptime is equal to 8322 hrs.	
Estimated net power output in kWe	65.0	P+ net output in kWe	
Fan radiator offset	25.0	Power savings from fan radiator	
Average Total Net Power Output in kWe	90.0	Average Total Net Annual Power Output in kWe	
Annual value of power produced by P+	\$ 209,714	1st year annual revenue from P+ Generator [\$17476 Gross per month]	
AVG annual P+ O&M expense based on \$0.015 per kWh	\$ 8,291	Operation and maintenance expenses based on projected lifetime	
Simple Payback in Years	3.12	Years (this does account for 0% increase \$/kWh for electricity	
Projected lifetime	20	Years	
Estimated % annual increase in \$/kWh	0.00%	Estimated percentage per year in increased power costs	
Projected Lifetime Net Revenue	\$ 3,400,473	Based on 0.00% increase in power costs per year	
Total cost per kWh over lifetime	\$ 0.0573	Total cost over lifetime including O&M costs of \$0.015 per kWh	
IRR for projected lifetime	32.22%	Internal Rate of Return for 20.0 years	
Net Present Value of Investment over 20 Years	\$ 3,400,473	Based on inflation rate of 0.00%	

This document contains confidential and proprietary information and is supplied purely to enable you to evaluate details concerning ElectraTherm products and services. No part of this document may be disclosed or transferred

Economics running 6000 hours of run time annually



\$	Single Currency
\$ x 1 = \$	CONFIDENTIAL
1.00	Payback Estimator

Expand Null Values

Collapse Null Values

Series 6000 Power+ Generator	\$ 410,000	Power+ Generator
Water plumbing	\$ 20,000	Plumbing, piping, connections, valves and assembly
Electrical components and hookup	\$ 15,000	Electrical conduit, wiring, and component installation
Exhaust gas heat exchanger	\$ 125,000	Exhaust gas heat exchanger, pump, and plumbing if required
Radiator with a payback option	\$ 15,000	Additional HX / Pump / BOP
misc expense	\$ 10,000	misc.
Commissioning and startup of P+	\$ 8,000	Technicians with travel expenses for two days
Shipping Power+ Generator	\$ 25,000	Estimated shipping of P+ to site
Estimated Total Capital Expenditure (CapEx)	\$ 628,000	Estimated Total CapEx for this Project
CapEx including Incentives	\$ 628,000	CapEx including Incentives
Total value of power per kWh	\$ 0.28	Average value of kWh produced
Percentage of uptime hours (100% max/8760hrs)	68%	68% uptime is equal to 5957 hrs.
Estimated net power output in kWe	65.0	P+ net output in kWe
Fan radiator offset	25.0	Power savings from fan radiator
Average Total Net Power Output in kWe	90.0	Average Total Net Annual Power Output in kWe
Annual value of power produced by P+	\$ 150,111	1st year annual revenue from P+ Generator [\$12509 Gross per month]
AVG annual P+ O&M expense based on \$0.014 per kWh	\$ 5,606	Operation and maintenance expenses based on projected lifetime
Simple Payback in Years	4.36	Years (this does account for 0% increase \$/kWh for electricity)
Projected lifetime	20	Years
Estimated % annual increase in \$/kWh	0.00%	Estimated percentage per year in increased power costs
Projected Lifetime Net Revenue	\$ 2,262,106	Based on 0.00% increase in power costs per year
Total cost per kWh over lifetime	\$ 0.0730	Total cost over lifetime including O&M costs of \$0.014 per kWh
IRR for projected lifetime	22.80%	Internal Rate of Return for 20.0 years
Net Present Value of Investment over 20 Years	\$ 2,262,106	Based on inflation rate of 0.00%

This document contains confidential and proprietary information and is supplied purely to enable you to evaluate details concerning ElectraTherm products and services. No part of this document may be disclosed or transferred

What we will do

1. Site visit and then send you a Preliminary Engineering Proposal for your engines
2. Offer to have our technicians come to site and measure mass flow
3. After measurement give an installation proposal
4. Offer you an ongoing service contract to be included with the purchase

Upon contract approval:

- Come to site and install all equipment
- Train your team on preventative maintenance upon request
- Station our technician in Oceana for ongoing service and support
- Remotely monitor the running of the ORC with service contract

In Summary

ElectraTherm's Heat to Power Generator Delivers:

- Distributed, renewable power production
- Ease of installation, operation and maintenance
- Low operational costs with strong ROI
- Robust, reliable, off-the-shelf components
- A modular solution that can scale to the heat source
- Digital controls with remote monitoring & standard interface

Thank you!

**Rob Emrich, Director Sales and
Market Development**

**ElectraTherm
remrich@electratherm.com**